



LEAD LAG CONTROL PANEL

PRODUCT DATA & INSTALLATION

MODEL TLC

ELECTRICAL POWER:

115/1/60, 208-230/1/60, 200-220/1/50

Bulletin T40-TLC-PDI-3

1068826

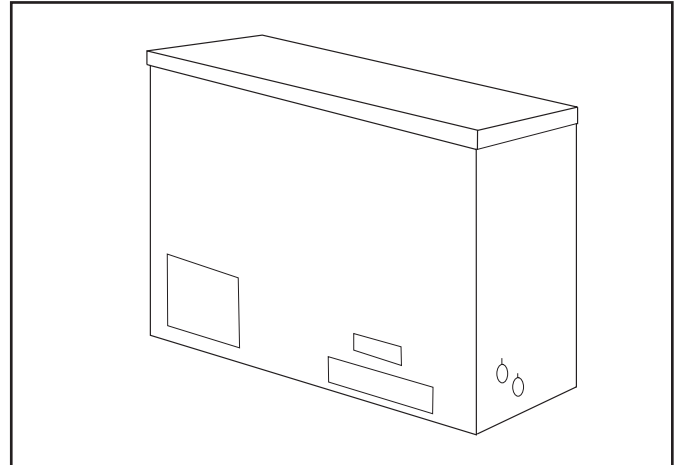

- For use on TWO independent refrigeration systems using pumpdown control mode. (Thermostat wired into liquid line solenoid valve).

- Panel can be mounted at condensing unit on indoor installations or can be mounted remote inside on a wall when used with outdoor condensing units.

- Designed to alternate each system automatically at a preset 24 hour time period. (can be readjusted from a 6 to 300 hour time period).

Three position toggle switch provides:

1. Condensing Unit #1 runs only.
2. Lead Lag mode. (alternates unit #1 and unit #2 automatically).
3. Condensing unit #2 runs only.

- TLC1 model offers low cost simple operation by automatically (pre-set time) or manually alternating each unit.

- TLC2 model offers the same as TLC1 and includes supplemental refrigeration backup during abnormal load situations or in the event one refrigeration system fails. (Includes alarm dry contacts)

- Panel is suitable for use with Air, Electric and Hot Gas defrost systems.

NOMENCLATURE

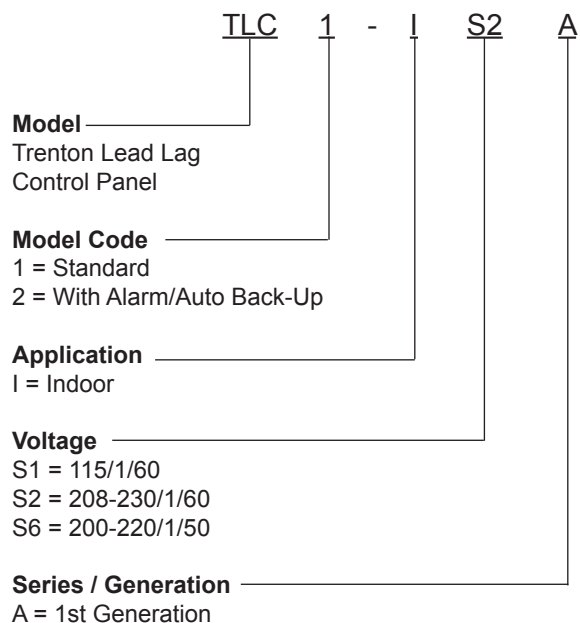

TYPICAL SYSTEM LEAD-LAG WIRING

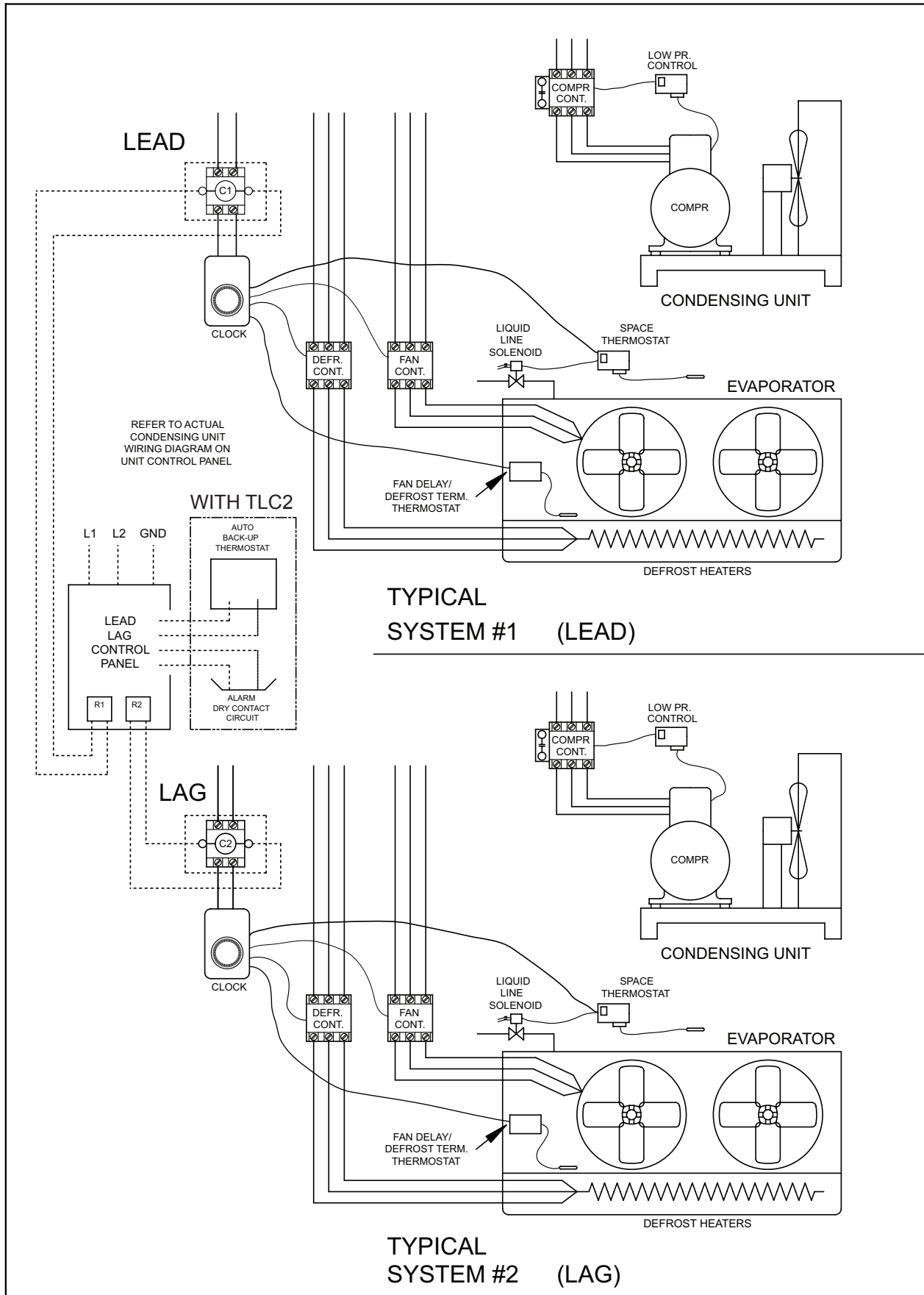

TYPICAL SYSTEM #1 (LEAD)

TYPICAL SYSTEM #2 (LAG)

CONTROL PANEL WIRING DIAGRAM: 230-1-60 Hz

LEAD-LAG CONTROL PANEL- STANDARD BASIC PANEL 230V CONTROL CIRCUIT

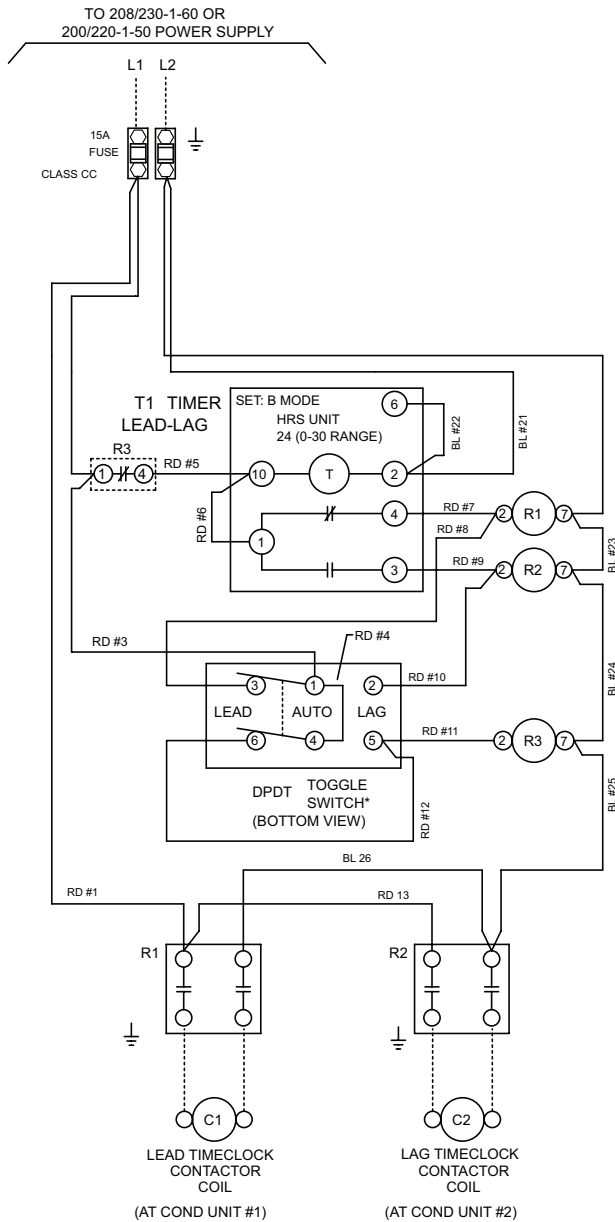

CONTROL PANEL COMPONENT LAYOUT

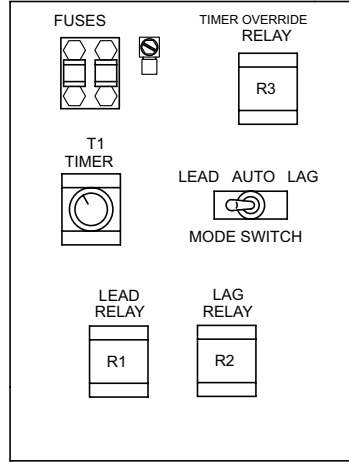

*
LEAD AUTO LAG
MODE SWITCH
(TOP VIEW)

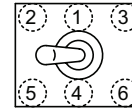

NOTES

1. USE COPPER CONDUCTORS ONLY
2. USE 90°C WIRE (OR HIGHER)
3. OPTIONAL COMPONENT MAY BE FACTORY INSTALLED OR SUPPLIED BY OTHERS
4. HEATER LOADS ARE NOT CONCURRENT WITH REFRIGERATION LOADS.
5. OVERCURRENT PROTECTION FOR EACH EVAPORATOR MUST NOT EXCEED MAXIMUM VALUE SHOWN ON EVAPORATOR NAMEPLATES.
6. MAY BE FACTORY INSTALLED-MOUNTED AND WIRED ON EVAPORATOR (PRE-ASSEMBLED MODELS) ON MULTIPLE PRE-ASSEMBLED EVAPORATORS WIRE SECOND EVAPORATOR SOLENOID IN PARALLEL WITH FIRST.
7. ALL FUSES TO BE CLASS CC OR J AND VOLTAGE RATED EQUAL (OR HIGHER) THAN OPERATING VOLTAGE.

CONDUCTORS/WIRING

- FACTORY WIRING
- WIRING BY OTHERS
- OPTIONAL COMPONENT WIRING (SOME OPTIONAL COMPONENTS MAY BE FACTORY WIRED.)

G=GREEN RD=RED BL=BLUE ALL OTHER BLACK

ALL FIELD WIRING MUST BE DONE IN COMPLIANCE WITH ALL APPLICABLE LOCAL AND NATIONAL CODES.

DATE:	DIAGRAM NUMBER
Feb7/07	CPB-S2-TLC1

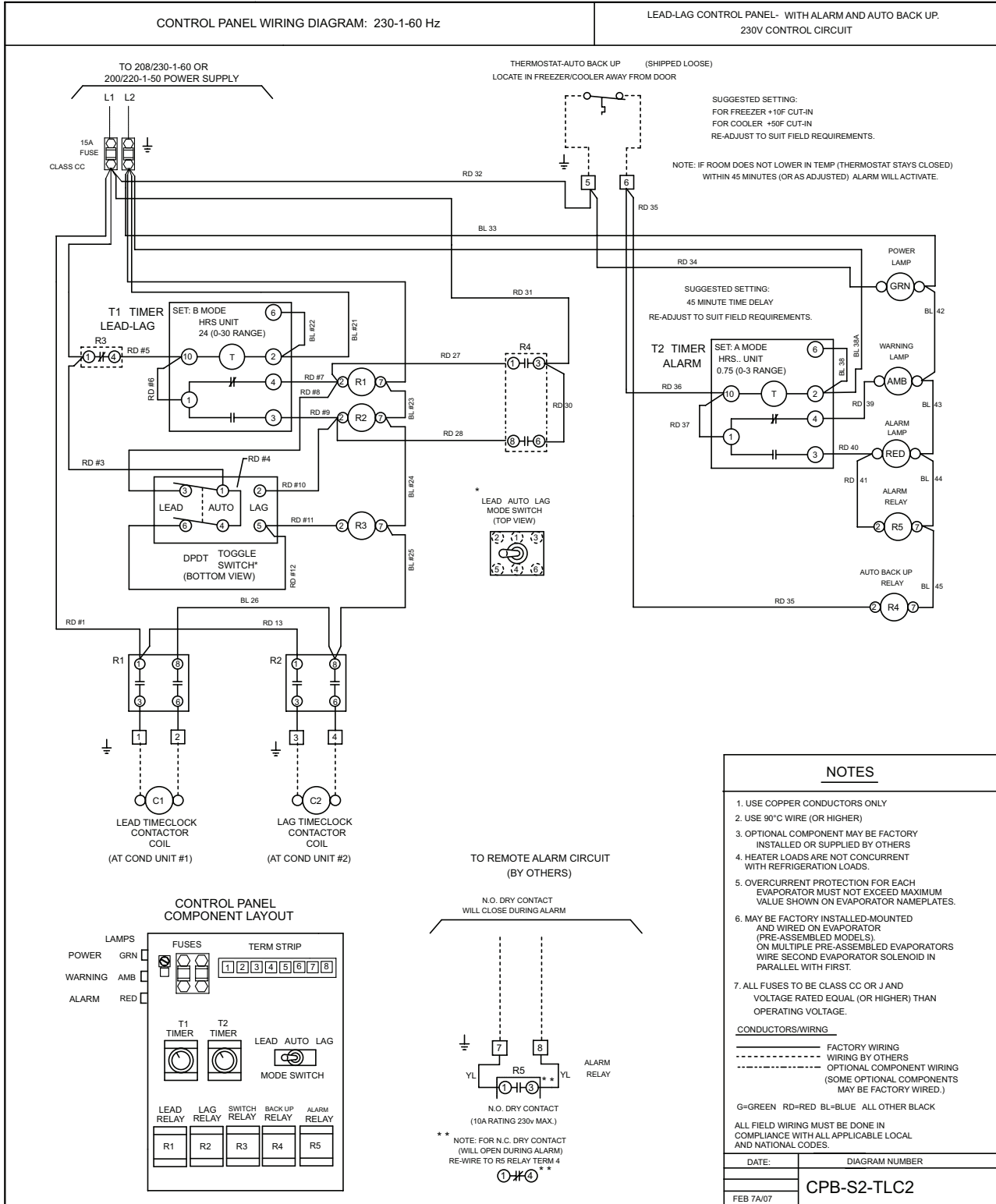



SERVICE PARTS LIST (50/60Hz)

TLC1 & TLC2

DESCRIPTION	120V	230V
Timeclock power Contactors (C1, C2)	1043345	1049602
Lead-Lag Timer (Dual volt/Freq) - T1	1065232	1065232
11 Pin Socket Base	1065233	1065233
Control Relay (R3)	1047767	104534
8 pin Socket Base	1062258	1062258
Lead / Lag Relay (R1, R2)	1043345	1049602
3 Position Toggle Switch	1067407	1067407

TLC2 ONLY

DESCRIPTION	120V	230V
Lead-Lag Timer (Dual volt/Freq) - T2	1065232	1065232
Control Relay (R4, R5)	1047767	104534
Alarm Temperature Control	1085500	1085500
Lamp - Red	1090031	1090273
Lamp - Green	1090032	1090274
Lamp - Amber	1090033	1090275

NOTES

NOTES



NATIONAL REFRIGERATION & AIR CONDITIONING CANADA CORP.
159 Roy Blvd. Brantford Ontario, Canada N3R 7K1
PHONE: (519) 751-0444 800-463-9517 FAX (519) 753-1140

Due to National Refrigeration's policy of continuous product improvement, we reserve the right to make changes without notice.

