



TLV LOW VELOCITY UNIT COOLERS

SPECIFICATIONS INSTALLATION, OPERATION AND MAINTENANCE MANUAL

HIGH TEMPERATURE

35°F (2°C) or Above Box Temperature and

MEDIUM TEMPERATURE

28°F TO 34°F Box Temperature (-2°C TO 1°C)

DEFROST TYPES:

Air, Electric or Hot gas Defrost

1073478

BULLETIN T30-TLV-PDI-21

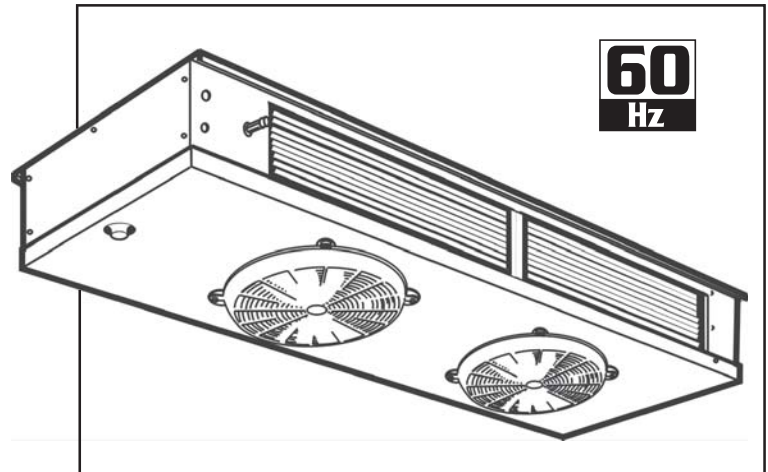

- Heavy gauge textured aluminum cabinet construction resists scratches/corrosion and minimizes weight for shipment, installation and service.
- High-efficiency PSC motors.
- Specially designed for quiet operation - ideal for prep. rooms.
- Capacity up to 37,000 BTUH nominal.
- Dual refrigeration coils with two-way air distribution reduces air velocities to minimize product dehydration.
- Reduced operating charge with 3/8" OD tubing
- Spacious end compartment allows for easy component installation.
- Attractive and durable high - density poly propylene fan guards.
- Hinged drain pan provides convenient access for cleaning.
- Terminal board allows for easy electrical connections.
- Refrigerants R22, R404A, R507 and R134a.
- Options:
 - Factory mounted solenoid valve, TXV and Thermostat.
 - Fin material and special coatings.
 - Energy Efficient EC Motors
 - Other options available - consult factory.

NOMENCLATURE

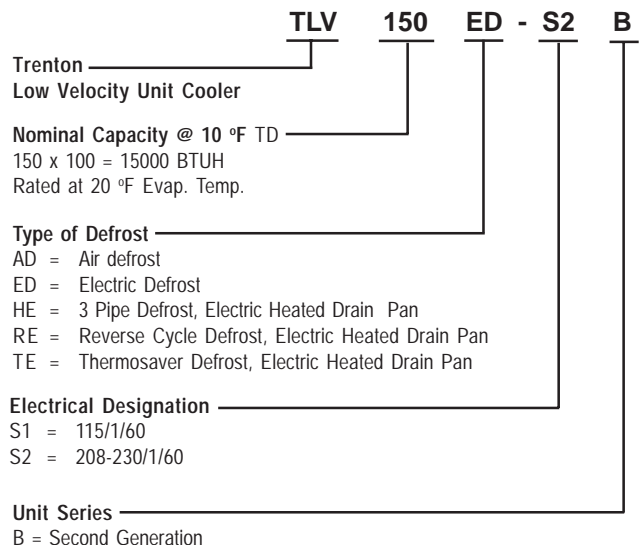

CONTENTS	PAGE
Nomenclature.....	Cover
Capacity Data	2
Electrical Data	3
Dimensional Data.....	4
Installation Clearances.....	5
Wiring Diagrams.....	6 - 10
TXV/Distributor Nozzle Selection.....	11
Defrost Control Positions.....	12
Installation Instructions.....	13 - 15
Service Parts List.....	15
Service Log.....	18
Warranty.....	19
Project Information.....	19
"As Built" Service Parts List.....	Back

CAPACITY DATA

60Hz

High Temp. Model	060AD	090AD	120AD	150AD	180AD	220AD	270AD	300AD	340AD	370AD	
Electric Defrost Model	060ED	090ED	120ED	150ED	180ED	220ED	270ED	300ED	340ED	370ED	
Hot Gas Defrost Model	60 [‡]	90 [‡]	120 [‡]	150 [‡]	180 [‡]	220 [‡]	270 [‡]	300 [‡]	340 [‡]	370 [‡]	
*Capacity	BTUH @ 1°F T.D.	600	900	1200	1500	1800	2200	2700	3000	3400	3700
	(WATTS @ 0.55°C T.D.)	(175.7)	(263.5)	(351.4)	(439.2)	(527.1)	(644.2)	(790.6)	(878.4)	(995.6)	(1083.4)
*Capacity	BTUH @ 10°F T.D.	6000	9000	12000	15000	18000	22000	27000	30000	34000	37000
	(WATTS @ 5.55°C T.D.)	(1756.9)	(2635.3)	(3513.7)	(4392.2)	(5270.6)	(6441.8)	(7905.9)	(8784.3)	(9955.6)	(10834)
*Capacity	BTUH @ 15°F T.D.	9000	13500	18000	22500	27000	33000	40500	45000	51000	55500
	(WATTS @ 8.33°C T.D.)	(2635.3)	(3952.9)	(5270.6)	(6588.2)	(7905.9)	(9662.7)	(11858.8)	(13176.5)	(14933.3)	(16251)
Air Flow	CFM	850	1120	1500	2000	2530	2785	3400	4000	4370	4840
	(L/S)	(401)	(529)	(708)	(944)	(1194)	(1314)	(1605)	(1888)	(2062)	(2284)
Refrigerant Charge **	LB.	2.6	4.4	6.5	7.3	8.0	10.2	10.0	12.0	15.3	15.3
	(KG)	(1.2)	(2.0)	(3.0)	(3.3)	(3.6)	(4.6)	(4.5)	(5.5)	(7.0)	(7.0)
Std. Unit Net Weight (w/o Refrigerant)	LB.	90	105	139	158	220	235	257	270	280	290
	(KG)	(41)	(48)	(63)	(72)	(100)	(107)	(117)	(123)	(127)	(132)

* Capacity rated with R22 @ +20°F (-6.6°C) S.S.T.

** R22 @ +20°F (-6.6°C) S.S.T. with coil 30 % full of liquid.

‡ Refer to Hot Gas Defrost nomenclature and insert appropriate code

NOTE: Defrost heaters can be field converted to operate on 208-230/3/60

ELECTRICAL DATA

60Hz

Air Defrost Models - 115/1/60

Model	No. of Fans	Standard PSC Motor				Optional EC Motor			
		FLA	MCA*	Watts	MOP	FLA	MCA*	Watts	MOP
TLV 060AD	1	1.1	1.4	90	15	0.8	1.0	55	15
TLV 090AD	1	1.1	1.4	130	15	1.6	2.0	95	15
TLV 120AD	2	2.2	2.5	180	15	1.6	1.8	110	15
TLV 150AD	2	2.2	2.5	260	15	3.2	3.6	190	15
TLV 180AD	3	3.3	3.6	270	15	2.4	2.6	165	15
TLV 220AD	3	3.3	3.6	390	15	4.8	5.2	285	15
TLV 270AD	3	3.3	3.6	390	15	4.8	5.2	285	15
TLV 300AD	4	4.4	4.7	520	15	6.4	6.8	380	15
TLV 340AD	4	4.4	4.7	520	15	6.4	6.8	380	15
TLV 370AD	5	5.5	5.8	650	15	8.0	8.4	475	15

FLA = Full Load Amps MCA = Minimum Circuit Ampacity MOP = Maximum Over Current Protection

* Electrical wiring is to be sized in accordance with minimum circuit ampacity

Air Defrost Models - 208-230/1/60

Model	No. of Fans	Standard PSC Motor				Optional EC Motor			
		FLA	MCA*	Watts	MOP	FLA	MCA*	Watts	MOP
TLV 060AD	1	0.5	0.6	90	15	0.5	0.6	55	15
TLV 090AD	1	0.5	0.6	130	15	1.0	1.3	95	15
TLV 120AD	2	1.0	1.1	180	15	1.0	1.1	110	15
TLV 150AD	2	1.0	1.1	260	15	2.0	2.3	190	15
TLV 180AD	3	1.5	1.6	270	15	1.5	1.6	165	15
TLV 220AD	3	1.5	1.6	390	15	3.0	3.3	285	15
TLV 270AD	3	1.5	1.6	390	15	3.0	3.3	285	15
TLV 300AD	4	2.0	2.1	520	15	4.0	4.3	380	15
TLV 340AD	4	2.0	2.1	520	15	4.0	4.3	380	15
TLV 370AD	5	2.5	2.6	650	15	5.0	5.3	475	15

FLA = Full Load Amps MCA = Minimum Circuit Ampacity MOP = Maximum Over Current Protection

* Electrical wiring is to be sized in accordance with minimum circuit ampacity

ELECTRICAL DATA

60Hz

Electric Defrost Models - 115/1/60

Model	No. of Fans	Fan Motors								Defrost Heaters			
		Standard PSC Motor				Optional EC Motor				Watts	FLA	MCA*	MOP
		FLA	MCA*	Watts	MOP	FLA	MCA*	Watts	MOP				
TLV 060ED	1	1.1	1.4	90	15	0.8	1.0	55	15	1880	16.4	20.4	25
TLV 090ED	1	1.1	1.4	130	15	1.6	2.0	95	15	1880	16.4	20.4	25

FLA = Full Load Amps MCA = Minimum Circuit Ampacity MOP = Maximum Over Current Protection

* Electrical wiring is to be sized in accordance with minimum circuit ampacity

Electric Defrost Models - 208-230/1/60

Model	No. of Fans	Fan Motors - 208-230/1/60								Defrost Heaters - 208/230/1/60				Defrost Heaters field converted to operate on 208-230/3/60			
		Standard PSC Motor				Optional EC Motor				Watts	FLA	MCA*	MOP	Watts	FLA	MCA*	MOP
		FLA	MCA*	Watts	MOP	FLA	MCA*	Watts	MOP								
TLV 060ED	1	0.5	0.6	90	15	0.5	0.6	55	15	1880	8.2	10.2	15	1880	4.9	6.1	15
TLV 090ED	1	0.5	0.6	130	15	1.0	1.3	95	15	1880	8.2	10.2	15	1880	4.9	6.1	15
TLV 120ED	2	1.0	1.1	180	15	1.0	1.1	110	15	3180	13.8	17.3	20	3180	8.5	10.6	15
TLV 150ED	2	1.0	1.1	260	15	2.0	2.3	190	15	3180	13.8	17.3	20	3180	8.5	10.6	15
TLV 180ED	3	1.5	1.6	270	15	1.5	1.6	165	15	4540	19.7	24.7	25	4540	12.1	15.1	20
TLV 220ED	3	1.5	1.6	390	15	3.0	3.3	285	15	4540	19.7	24.7	25	4540	12.1	15.1	20
TLV 270ED	3	1.5	1.6	390	15	3.0	3.3	285	15	4540	19.7	24.7	25	4540	12.1	15.1	20
TLV 300ED	4	2.0	2.1	520	15	4.0	4.3	380	15	4540	19.7	24.7	25	4540	12.1	15.1	20
TLV 340ED	4	2.0	2.1	520	15	4.0	4.3	380	15	5580	24.3	30.3	35	5580	14.9	18.6	20
TLV 370ED	5	2.5	2.6	650	15	5.0	5.3	475	15	5580	24.3	30.3	35	5580	14.9	18.6	20

FLA = Full Load Amps MCA = Minimum Circuit Ampacity MOP = Maximum Over Current Protection

* Electrical wiring is to be sized in accordance with minimum circuit ampacity

Hot Gas Defrost Models - 115/1/60

Model	No. of Fans	Standard PSC Motor					Optional EC Motor				
		Drain Pan Heater Watts	Heater Amps	Fan Motor FLA	MCA*	MOP	Drain Pan Heater Watts	Heater Amps	Fan Motor FLA	MCA*	MOP
TLV 060 HE/RE	1	580	5.0	1.1	6.3	15	580	5.0	0.8	6.6	15
TLV 090 HE/RE	1	580	5.0	1.1	6.3	15	580	5.0	1.6	6.6	15
TLV 120 HE/RE	2	580	5.0	2.2	6.3	15	580	5.0	1.6	6.6	15
TLV 150 HE/RE	2	580	5.0	2.2	6.3	15	580	5.0	3.2	6.6	15
TLV 180 HE/RE	3	820	7.1	3.3	8.9	15	820	7.1	2.4	9.4	15
TLV 220 HE/RE	3	820	7.1	3.3	8.9	15	820	7.1	4.8	9.4	15
TLV 270 HE/RE	3	820	7.1	3.3	8.9	15	820	7.1	4.8	9.4	15
TLV 300 HE/RE	4	820	7.1	4.4	8.9	15	820	7.1	6.4	9.4	15
TLV 340 HE/RE	4	1020	8.9	4.4	11.1	15	1020	8.9	6.4	11.6	15
TLV 370 HE/RE	5	1020	8.9	5.5	11.1	15	1020	8.9	8	11.6	15

FLA = Full Load Amps MCA = Minimum Circuit Ampacity MOP = Maximum Over Current Protection

* Electrical wiring is to be sized in accordance with minimum circuit ampacity

Hot Gas Defrost Models - 208-230/1/60

Model	No. of Fans	Standard PSC Motor					Optional EC Motor				
		Drain Pan Heater Watts	Heater Amps	Fan Motor FLA	MCA*	MOP	Drain Pan Heater Watts	Heater Amps	Fan Motor FLA	MCA*	MOP
TLV 060 HE/RE	1	580	2.5	0.5	3.2	15	580	2.5	0.5	2.9	15
TLV 090 HE/RE	1	580	2.5	0.5	3.2	15	580	2.5	1.0	2.9	15
TLV 120 HE/RE	2	580	2.5	1.0	3.2	15	580	2.5	1.0	2.9	15
TLV 150 HE/RE	2	580	2.5	1.0	3.2	15	580	2.5	2.0	2.9	15
TLV 180 HE/RE	3	820	3.6	1.5	4.5	15	820	3.6	1.5	4.1	15
TLV 220 HE/RE	3	820	3.6	1.5	4.5	15	820	3.6	3.0	4.1	15
TLV 270 HE/RE	3	820	3.6	1.5	4.5	15	820	3.6	3.0	4.1	15
TLV 300 HE/RE	4	820	3.6	2.0	4.5	15	820	3.6	4.0	4.1	15
TLV 340 HE/RE	4	1020	4.4	2.0	5.5	15	1020	4.4	4.0	5.1	15
TLV 370 HE/RE	5	1020	4.4	2.5	5.5	15	1020	4.4	5.0	5.1	15

FLA = Full Load Amps MCA = Minimum Circuit Ampacity MOP = Maximum Over Current Protection

* Electrical wiring is to be sized in accordance with minimum circuit ampacity

DIMENSIONAL DATA - Inches (mm)

- NOTES: 1) Dimensions shown in inches & (mm). These are typical for Air, Electric and Hot gas defrost models.
- 2) Electrical connection end is opposite to the piping end on all models.
- 3) 1/4" (6 mm) O.D. external equalizer line and service access fitting included on all suction headers inside end compartment

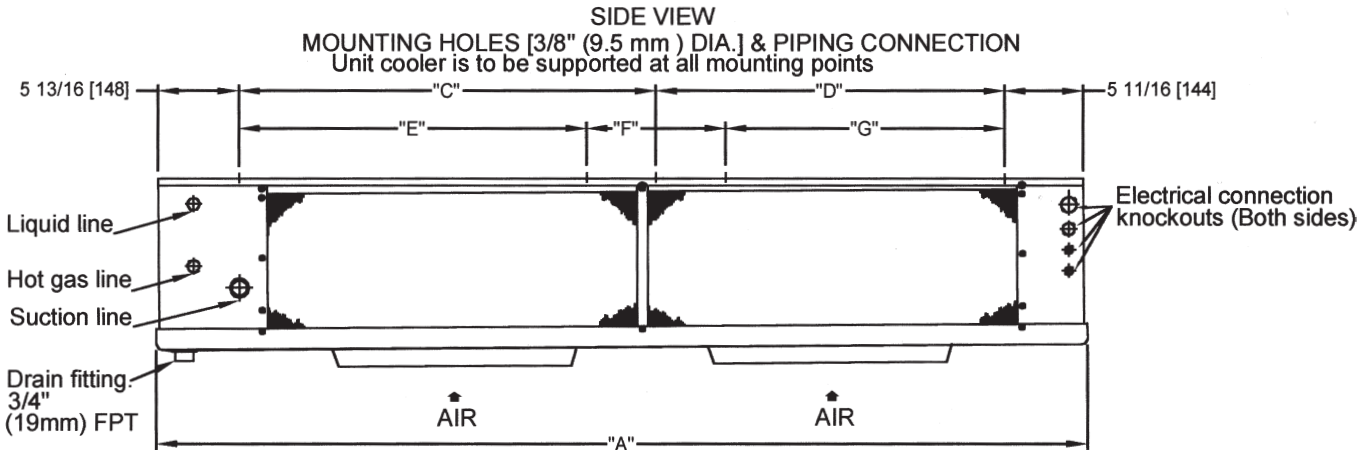
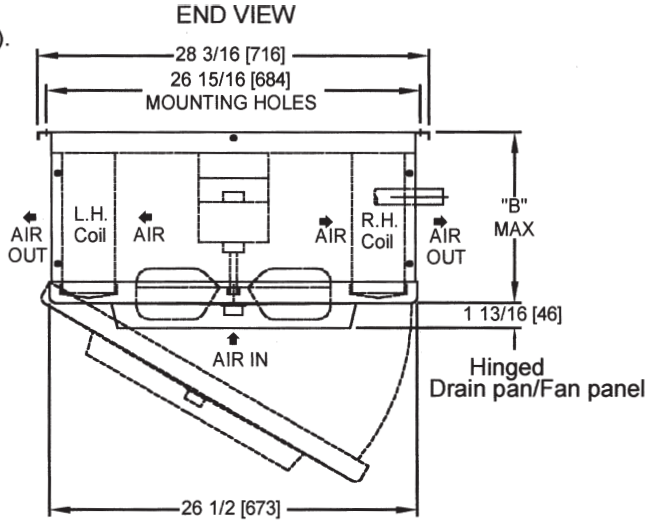

MODEL	No. of Fans	DIMENSIONAL DATA - INCHES (mm)									
		Suction Connection (OD)	Distributor Inlet (OD)	Hot Gas Side Conn. (OD)	A	B	Mounting Holes				
							C	D	E	F	G
060	1	5/8 (16)	1/2 (13)	1/2 (13)	66 7/8 (1699)	8 11/16 (221)	27 1/2 (699)	27 1/2 (699)	-	-	-
090	1	7/8 (22)	1/2 (13)	1/2 (13)	66 7/8 (1699)	9 9/16 (252)	27 1/2 (699)	27 1/2 (699)	-	-	-
120	2	7/8 (22)	1/2 (13)	1/2 (13)	66 7/8 (1699)	12 7/16 (316)	27 1/2 (699)	27 1/2 (699)	-	-	-
150	2	1 1/8 (29)	1/2 (13)	1/2 (13)	66 7/8 (1699)	14 15/16 (378)	27 1/2 (699)	27 1/2 (699)	-	-	-
180	3	1 1/8 (29)	1/2 (13)	1/2 (13)	92 7/8 (2359)	14 15/16 (378)	40 1/2 (1029)	40 1/2 (1029)	-	-	-
220	3	1 1/8 (29)	1/2 (13)	1/2 (13)	92 7/8 (2359)	14 15/16 (378)	40 1/2 (1029)	40 1/2 (1029)	-	-	-
270	3	1 1/8 (29)	* 7/8 (22)	5/8 (16)	92 7/8 (2359)	17 7/16 (443)	40 1/2 (1029)	40 1/2 (1029)	-	-	-
300	4	1 1/8 (29)	* 7/8 (22)	5/8 (16)	92 7/8 (2359)	17 7/16 (443)	40 1/2 (1029)	40 1/2 (1029)	-	-	-
340	4	1 3/8 (35)	* 7/8 (22)	5/8 (16)	112 7/8 (2867)	17 7/16 (443)	-	-	40 1/2 (1029)	20 (508)	40 1/2 (1029)
370	5	1 3/8 (35)	* 7/8 (22)	5/8 (16)	112 7/8 (2867)	17 7/16 (443)	-	-	40 1/2 (1029)	20 (508)	40 1/2 (1029)

* Reducer supplied to accommodate 1/2" or 7/8" TXV outlet connection.

RECOMMENDED INSTALLATION CLEARANCES

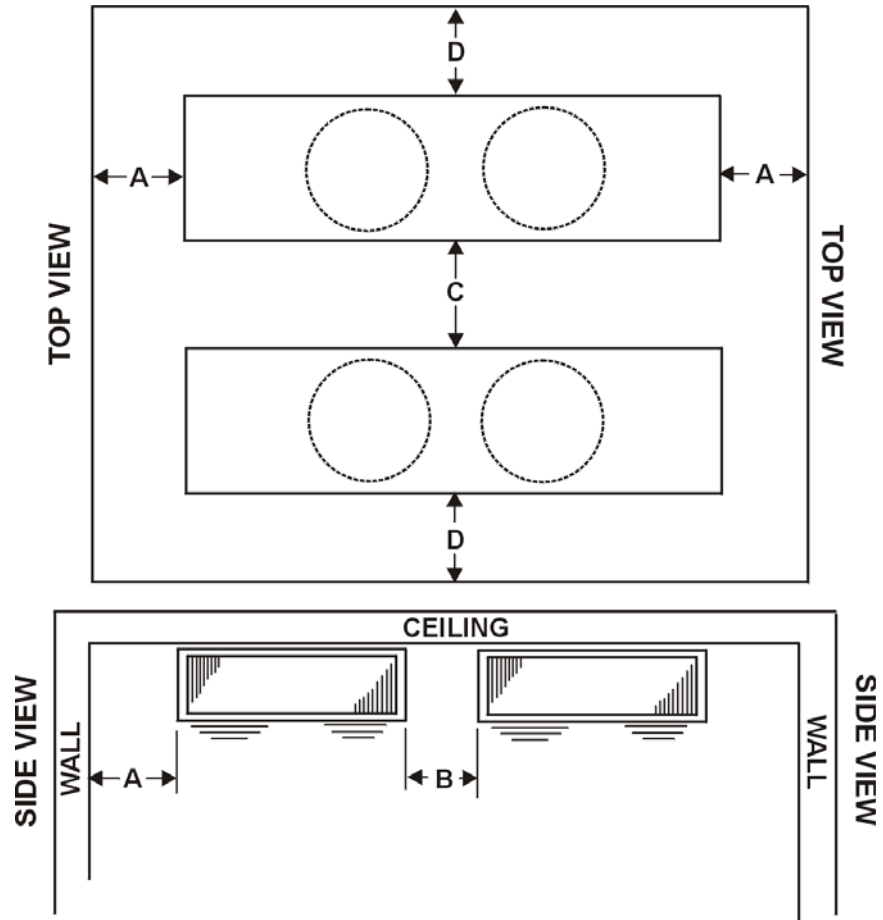

DIMENSION		A	B	C	D
Minimum	ft.	2	2	6	3
	(cm.)	(61)	(61)	(183)	(92)
Maximum	ft.	-	7	40	20
	(cm.)	-	(210)	(1200)	(600)

WIRING DIAGRAM

Air Defrost - All Voltages

AIR DEFROST

TYPICAL WIRING: FOR MULTIPLE EVAPORATORS AND OTHER
ALTERNATIVE WIRING, SEE INSTALLATION MANUAL

WITH DEFROST TIME CLOCK

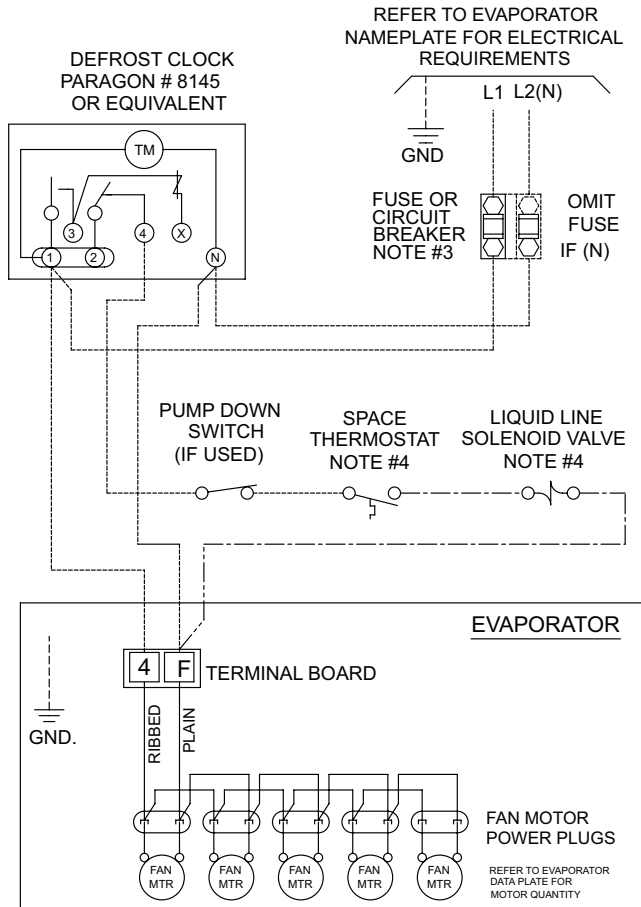

WITHOUT DEFROST TIME CLOCK

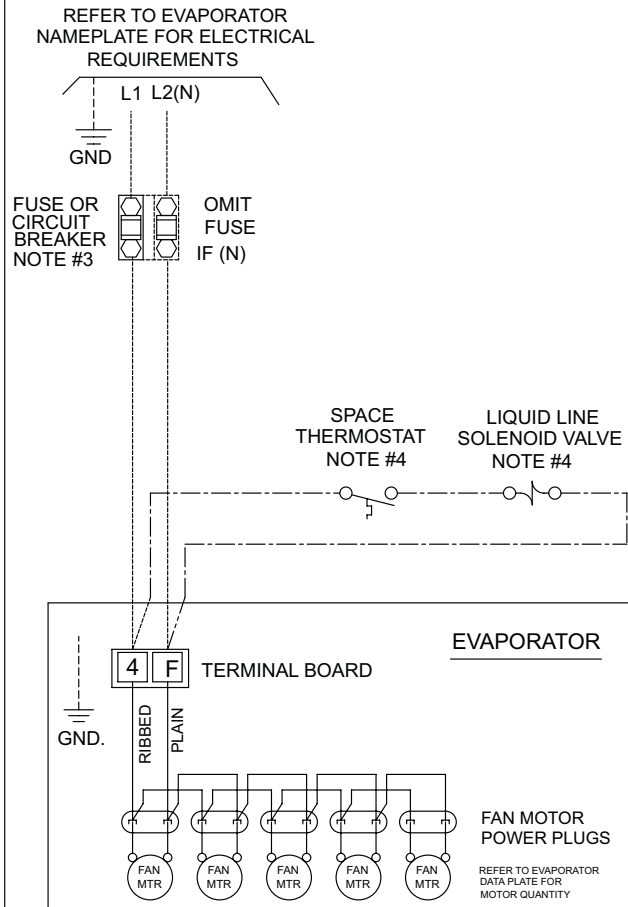

NOTES

- 1). USE COPPER CONDUCTORS ONLY
- 2). USE 75°C WIRE (OR HIGHER)
- 3). OVERCURRENT PROTECTION FOR EVAPORATOR FAN MOTORS AND DEFROST HEATERS MUST NOT EXCEED MAXIMUM VALUE SHOWN ON EVAPORATOR NAMEPLATE.
- 4). MAY BE FACTORY INSTALLED-MOUNTED AND WIRED ON EVAPORATOR (PRE-ASSEMBLED MODELS)

TERMINALS

- DH - DRAIN PAN HEATER
- - COMPONENT TERMINAL - MARKED
- ◻ - COMPONENT TERMINAL - UNMARKED (IDENTIFIABLE BY LOCATION)
- - COMPONENT TERMINAL - UNMARKED (UNIDENTIFIABLE)
- ◻ - TERMINAL BLOCK TERMINAL
- - WIRE SPLICE

CONDUCTORS/WIRING

- FACTORY WIRING
- WIRING BY OTHERS
- OPTIONAL FACTORY OR BY OTHERS

ALL FIELD WIRING MUST BE DONE IN COMPLIANCE WITH ALL APPLICABLE LOCAL AND NATIONAL CODES.

REV A
11/05/01
1073979

WIRING DIAGRAM

Electric Defrost - Single Evaporator

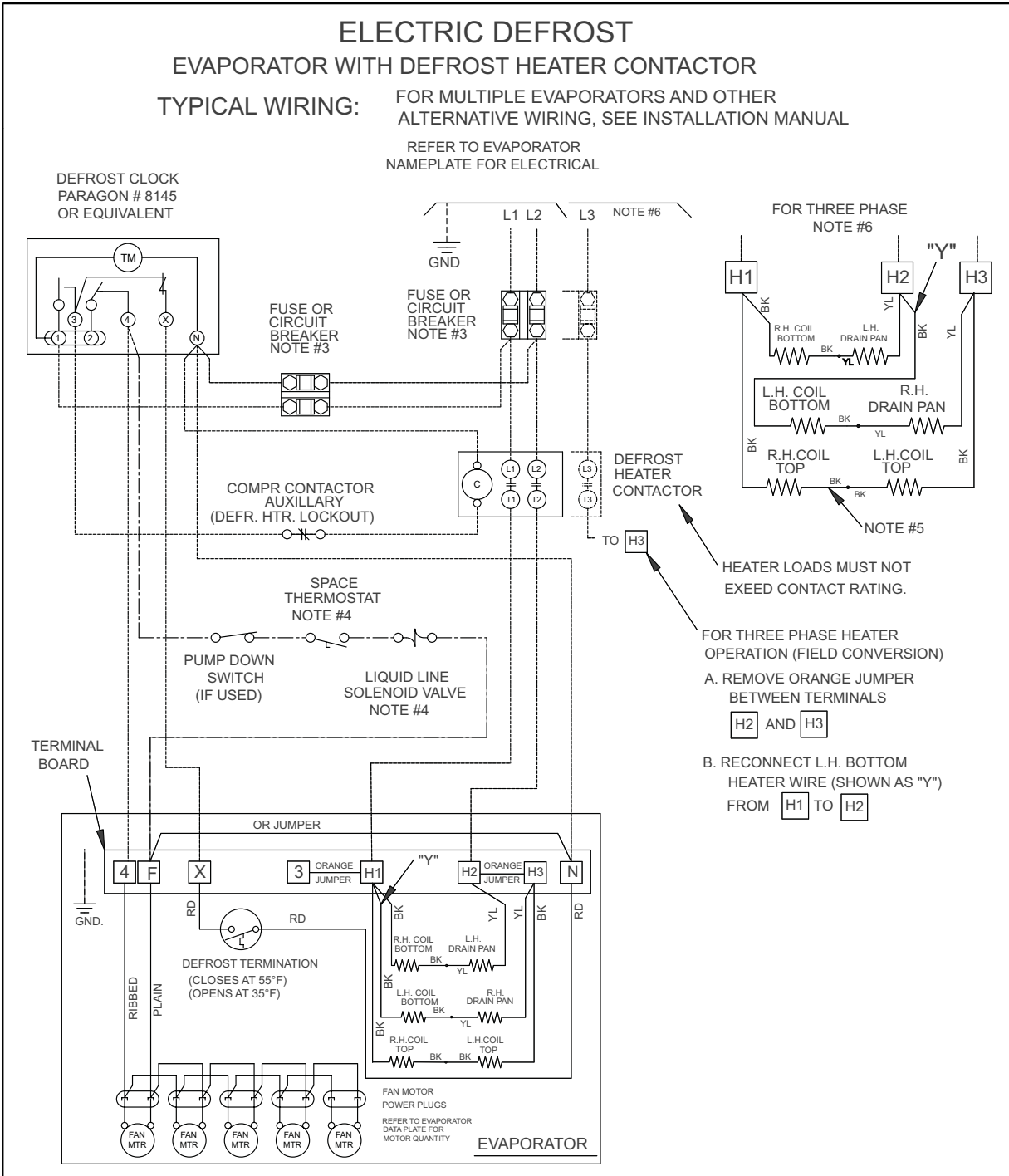

NOTES

1. USE COPPER CONDUCTORS ONLY
2. USE 75°C WIRE (OR HIGHER)
3. OVERCURRENT PROTECTION FOR EVAPORATOR FAN MOTORS AND DEFROST HEATERS MUST NOT EXCEED MAXIMUM VALUE SHOWN ON EVAPORATOR NAMEPLATE.
4. MAY BE FACTORY INSTALLED-MOUNTED AND WIRED ON EVAPORATOR (PRE-ASSEMBLED MODELS) ON MULTIPLE PRE-ASSEMBLED EVAPORATORS WIRE SECOND EVAPORATOR SOLENOID IN PARALLEL WITH FIRST ONE. ONLY USE ONE THERMOSTAT.
5. THESE HEATERS NOT USED ON _LV060ED AND _LV090ED MODELS

TERMINALS

- - COMPONENT TERMINAL - MARKED
- - COMPONENT TERMINAL - UNMARKED (IDENTIFIABLE BY LOCATION)
- - COMPONENT TERMINAL - UNMARKED (UNIDENTIFIABLE)
- - TERMINAL BLOCK TERMINAL
- - WIRE SPLICE

CONDUCTORS/WIRING

- FACTORY WIRING
- WIRING BY OTHERS
- OPTIONAL FACTORY OR BY OTHERS

ALL FIELD WIRING MUST BE DONE IN COMPLIANCE WITH ALL APPLICABLE LOCAL AND NATIONAL CODES.

REV B
11/05/01
1073978

WIRING DIAGRAM

Electric Defrost - Multiple Evaporators

FOR ALL MODELS USING DEFROST HEATER CONTACTOR

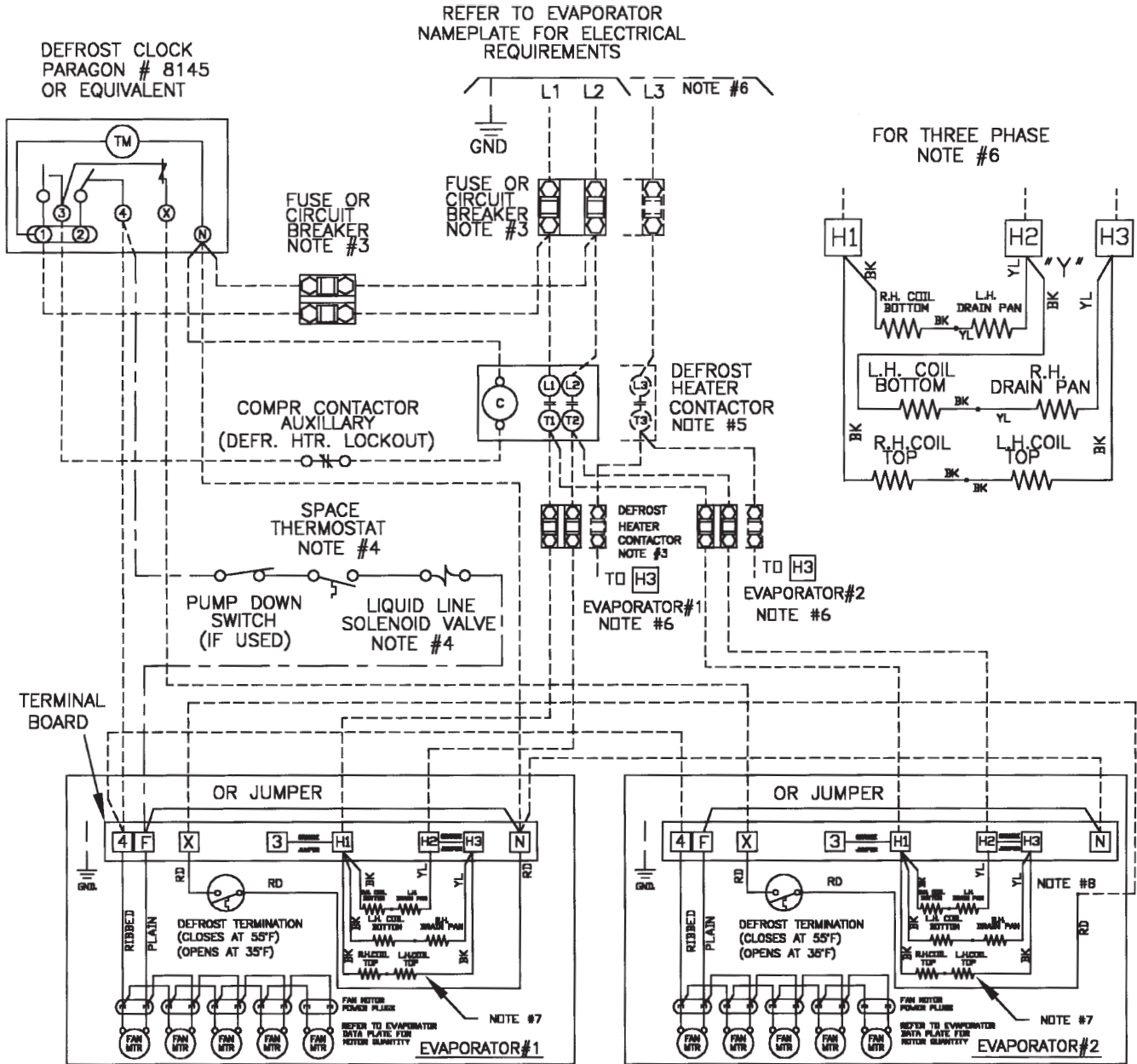

NOTES

- 1). USE COPPER CONDUCTORS ONLY
- 2). USE 60°C WIRE (OR HIGHER)
- 3). OVERCURRENT PROTECTION FOR EVAPORATOR FAN MOTORS AND DEFROST HEATERS MUST NOT EXCEED MAXIMUM VALUE SHOWN ON EVAPORATOR NAMEPLATE.
- 4). MAY BE FACTORY INSTALLED-MOUNTED AND WIRED ON EVAPORATOR (PRE-ASSEMBLED MODELS) ON MULTIPLE PRE-ASSEMBLED EVAPORATORS WIRE SECOND EVAPORATOR SOLENOID IN PARALLEL WITH FIRST ONE. ONLY USE ONE THERMOSTAT.

- 5). HEATER LOADS MUST NOT EXCEED CONTACT RATING.
- 6). FOR THREE PHASE HEATER OPERATION (FIELD CONVERSION)
 - A. REMOVE ORANGE JUMPER BETWEEN TERMINALS H2 AND H3
 - B. RECONNECT L.H. BOTTOM HEATER WIRE (SHOWN AS "Y") FROM H1 TO H2
- 7). TOP HEATERS NOT USED ON MODELS _LV060ED & _LV090ED
- 8). REMOVE RD WIRE FROM TERMINAL N AND SPLICE AS SHOWN

TERMINALS

- - COMPONENT TERMINAL - MARKED
- - COMPONENT TERMINAL - UNMARKED (IDENTIFIABLE BY LOCATION)
- - COMPONENT TERMINAL - UNMARKED (UNIDENTIFIABLE)
- - TERMINAL BLOCK TERMINAL
- - WIRE SPLICE

CONDUCTORS/WIRING

- FACTORY WIRING
- - - WIRING BY OTHERS
- · - OPTIONAL FACTORY OR BY OTHERS

ALL FIELD WIRING MUST BE DONE IN COMPLIANCE WITH ALL APPLICABLE LOCAL AND NATIONAL CODES.

REV 10/25/01

WIRING DIAGRAM

Electric Defrost - (For optional use on models 060ED and 090ED operating on 208-230/1/60)

ELECTRIC DEFROST

EVAPORATOR WITHOUT DEFROST HEATER CONTACTOR
USING MAX 15A HEATER OVERCURRENT PROTECTION

TYPICAL WIRING: FOR MULTIPLE EVAPORATORS AND OTHER ALTERNATIVE WIRING, SEE INSTALLATION MANUAL

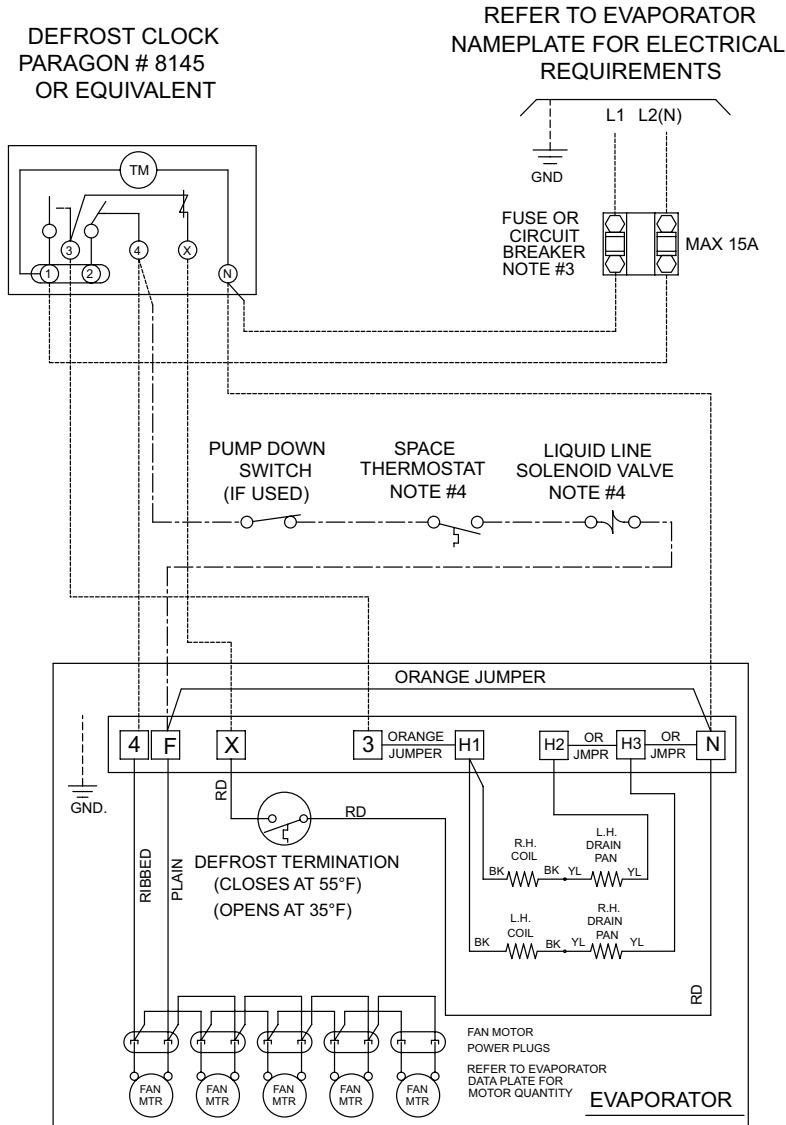

NOTES

- 1). USE COPPER CONDUCTORS ONLY
- 2). USE 75°C WIRE (OR HIGHER)
- 3). OVERCURRENT PROTECTION FOR EVAPORATOR FAN MOTORS AND DEFROST HEATERS MUST NOT EXCEED MAXIMUM VALUE SHOWN ON EVAPORATOR NAMEPLATE.
- 4). MAY BE FACTORY INSTALLED-MOUNTED AND WIRED ON EVAPORATOR (PRE-ASSEMBLED MODELS)
ON MULTIPLE PRE-ASSEMBLED EVAPORATORS WIRE SECOND EVAPORATOR SOLENOID IN PARALLEL WITH FIRST ONE. ONLY USE ONE THERMOSTAT.

TERMINALS

- - COMPONENT TERMINAL - MARKED (IDENTIFIABLE BY LOCATION)
- - COMPONENT TERMINAL - UNMARKED (UNIDENTIFIABLE)
- - TERMINAL BLOCK TERMINAL
- - WIRE SPLICE

CONDUCTORS/WIRING

- FACTORY WIRING
- WIRING BY OTHERS
- OPTIONAL FACTORY OR BY OTHERS

ALL FIELD WIRING MUST BE DONE IN COMPLIANCE WITH ALL APPLICABLE LOCAL AND NATIONAL CODES.

1074180
REV-A

WIRING DIAGRAM

Hot Gas Defrost - All Voltages

REVERSE CYCLE AND 3-PIPE HOT GAS DEFROST

REFER TO EVAPORATOR
NAMEPLATE FOR ELECTRICAL
REQUIREMENTS

*FOR 3-PIPE SEE NOTES #5 & 6

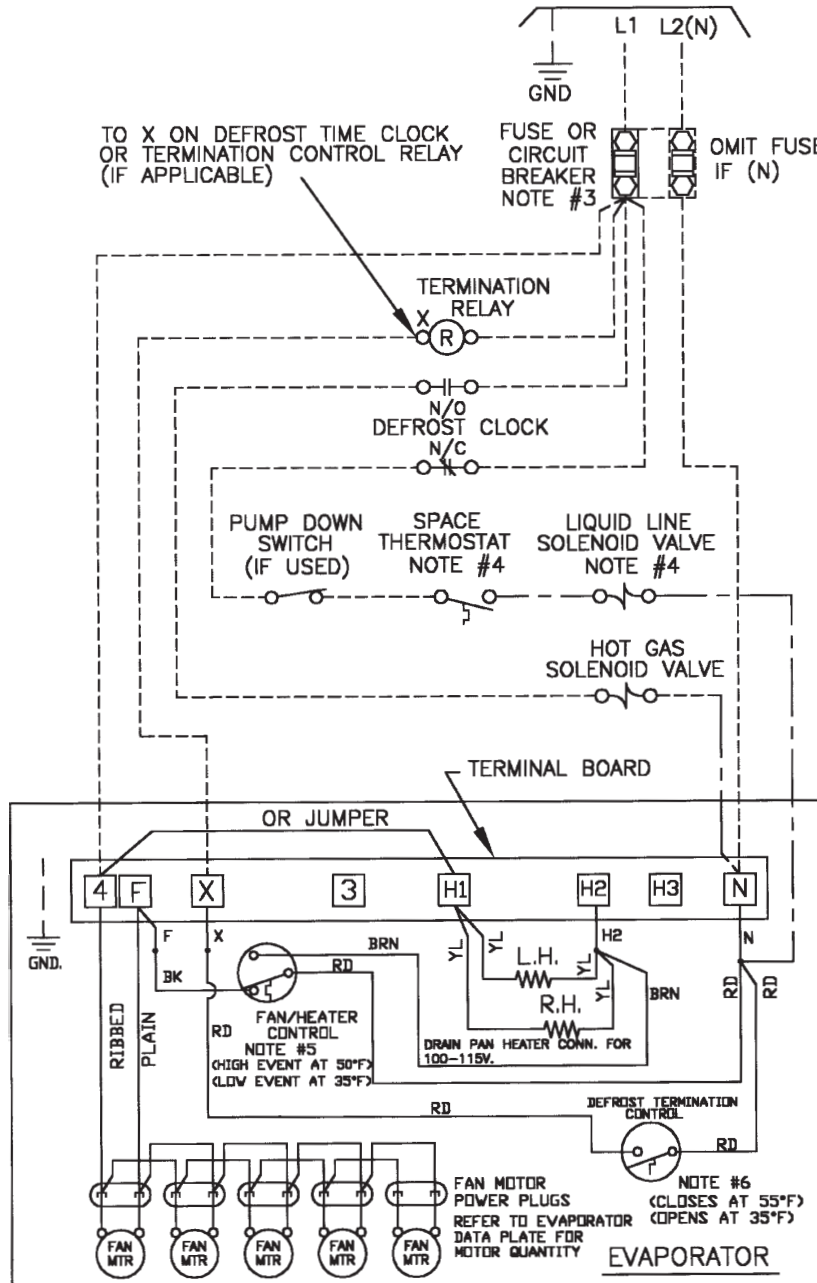

DRAIN PAN HEATER CONN.
FOR 200-230V

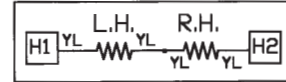

NOTES

- 1). USE COPPER CONDUCTORS ONLY
- 2). USE 60°C WIRE (OR HIGHER)
- 3). OVERCURRENT PROTECTION FOR EVAPORATOR FAN MOTORS AND DEFROST HEATERS MUST NOT EXCEED MAXIMUM VALUE SHOWN ON EVAPORATOR NAMEPLATE.
- 4). MAY BE FACTORY INSTALLED-MOUNTED AND WIRED ON EVAPORATOR (PRE-ASSEMBLED MODELS).
- 5). FAN/HEATER CONTROL IS INSTALLED ON THE SUCTION LINE LOCATION FOR REVERSE CYCLE AND MUST BE MOVED TO THE DISTRIBUTOR SIDE PORT LOCATION FOR 3-PIPE HOT GAS DEFROST.
- 6). DEFROST TERMINATION CONTROL IS INSTALLED AT THE DISTRIBUTOR SIDE PORT LOCATION FOR REVERSE CYCLE AND MUST BE MOVED TO THE SUCTION LINE LOCATION FOR 3-PIPE HOT GAS DEFROST.

TERMINALS

- DH - DRAIN PAN HEATER
- - COMPONENT TERMINAL - MARKED
- - COMPONENT TERMINAL - UNMARKED (IDENTIFIABLE BY LOCATION)
- - COMPONENT TERMINAL - UNMARKED (UNIDENTIFIABLE)
- - TERMINAL BLOCK TERMINAL
- - WIRE SPLICE

CONDUCTORS/WIRING

- FACTORY WIRING
- WIRING BY OTHERS
- OPTIONAL FACTORY OR BY OTHERS

ALL FIELD WIRING MUST BE DONE IN COMPLIANCE WITH ALL APPLICABLE LOCAL AND NATIONAL CODES.

REV 11/03/01

NOTE: DURING THE HOT GAS DEFROST CYCLE, THE FAN/HEATER CONTROL DE-ENERGIZES THE EVAPORATOR FANS AND ENERGIZES THE DRAIN PAN HEATERS, ANYTIME TEMPERATURE OF INCOMING REFRIGERANT GAS IS ABOVE 50°F

THERMOSTATIC EXPANSION VALVE SELECTION - SPORLAN

MODEL NO.	TD °F	TD (°C)	R22	R404A	R507
060	10	(5.6)	EGVE-3/4-C	EGSE-1/2-C	EGPE-1/2-C
	15	(8.3)			EGPE-1-C
090	10	(5.6)	EGVE-1-C	EGSE-1-C	EGPE-1-C
	15	(8.3)			EGPE-1-C
120	10	(5.6)	EGVE-1 1/2-C	EGSE-1 1/2-C	EGPE-1 1/2-C
	15	(8.3)			EGPE-1 1/2-C
150	10	(5.6)	EGVE-2-C	EGSE-2-C	EGPE-2-C
	15	(8.3)			EGPE-2-C
180	10	(5.6)	EGVE-3-C	SSE-3-C	SPE-3-C
	15	(8.3)			SPE-3-C
220	10	(5.6)	SVE-4-C	SSE-4-C	SPE-4-C
	15	(8.3)			SPE-4-C
270	10	(5.6)	SVE-4-C	SSE-4-C	SPE-4-C
	15	(8.3)			SPE-4-C
300	10	(5.6)	SVE-4-C	SSE-4-C	SPE-4-C
	15	(8.3)			SPE-4-C
340	10	(5.6)	SVE-4-C	SSE-4-C	SPE-4-C
	15	(8.3)			SPE-4-C
370	10	(5.6)	SVE-4-C	SSE-4-C	SPE-4-C
	15	(8.3)			SPE-4-C

SELECTIONS BASED ON 100°F(37.7°C) LIQUID

DISTRIBUTOR NOZZLE SELECTION

STANDARD NOZZLES FACTORY INSTALLED FOR ALL MODELS	
T.D.	8 °F TO 12 °F (4.4 °C to 6.6 °C)
EVAP. TEMP. RANGE	18 °F TO 40 °F (-7.7 °C TO 4.4 °C)
REFRIGERANT	R22, R-404A, R507
060	L-3/4
090	L- 1
120, 150	L-1 1/2
180	L- 2
220	L-2 1/2
270	G- 2 1/2
300	G- 3
340, 370	G-4

SELECTIONS BASED ON 100 °F(37.7 °C) LIQUID

FAN/HEATER CONTROL AND DEFROST TERMINATION CONTROL POSITION

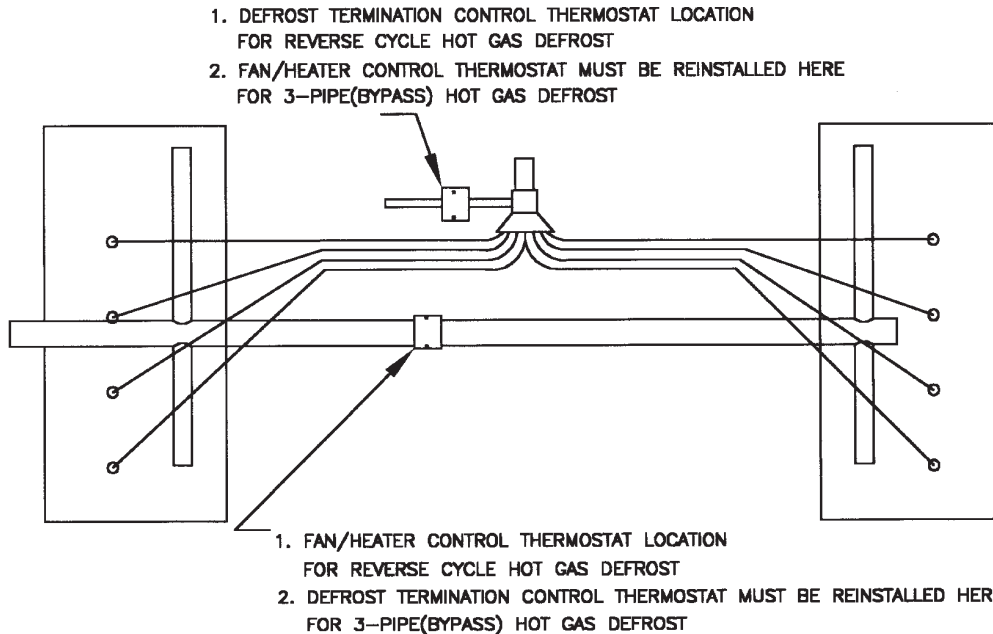

FIGURE 1

UNIT COOLER WILL LEAVE THE FACTORY WITH THE FAN/HEATER AND DEFROST TERMINATION CONTROL THERMOSTAT INSTALLED IN THE REVERSE CYCLE POSITION*

HOT GAS DEFROST (REVERSE CYCLE)

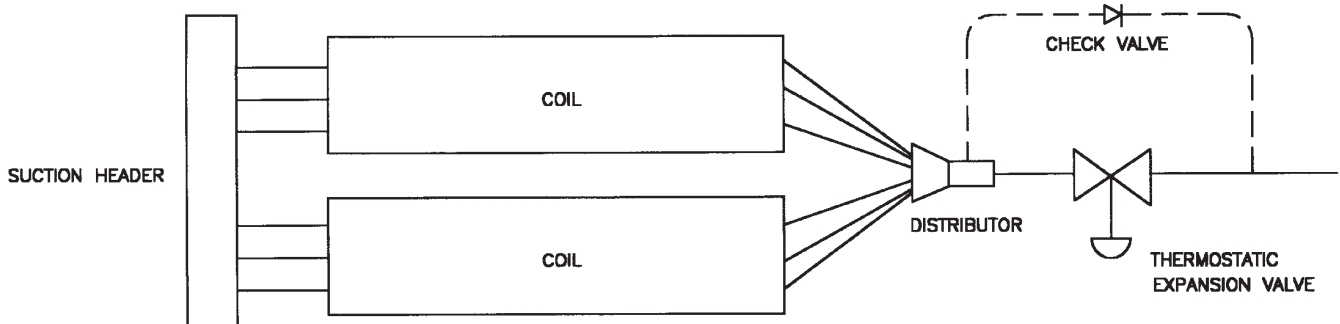

FIGURE 2

UNIT COOLER SHOWING HOT GAS LINE AND CHECK VALVE AROUND EXPANSION VALVE AS USED FOR REVERSE CYCLE HOT GAS DEFROST

HOT GAS DEFROST (3-PIPE OR BYPASS)

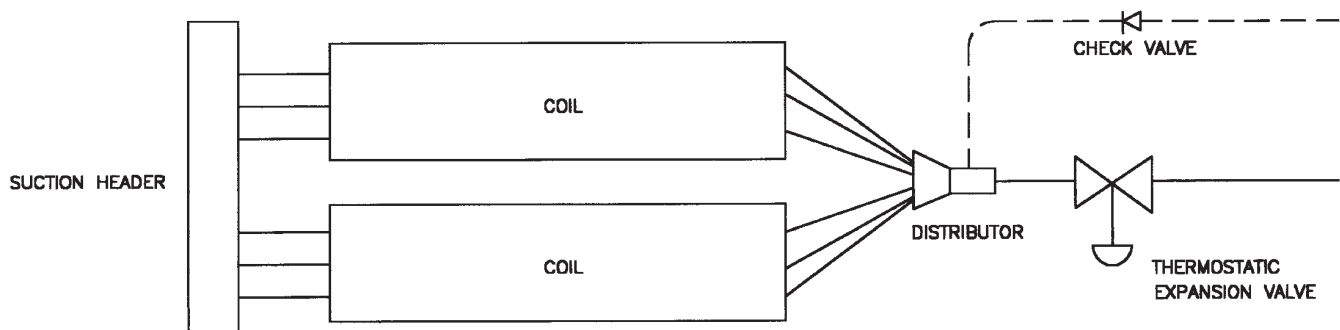

FIGURE 3

INSTALLATION INSTRUCTIONS

INSTALLATION

The installation and start-up of LV Unit Coolers should only be performed by qualified refrigeration mechanics.

This equipment should be installed in accordance with all applicable codes, ordinances and local by-laws.

INSPECTION

Inspect all equipment before unpacking for visible signs of damage or loss. Check shipping list against material received to ensure shipment is complete.

IMPORTANT: Remember, you, the consignee, must make any claim necessary against the transportation company. Shipping damage or missing parts, when discovered at the outset, will prevent later unnecessary and costly delays.

If damage or loss during transport is evident, make claim to carrier, as this will be their responsibility, not the manufacturer's.

Should carton be damaged, but damage to equipment is not obvious, a claim should be filed for "concealed damage" with the carrier.

IMPORTANT: The electrical characteristics of the unit should be checked at this time to make sure they correspond to those ordered and to electrical power available at the job site.

Save all shipping papers, tags and instruction sheets for reference by installer and owner.

APPLICATION

LV Unit Coolers are designed for use with R22, R404A, R134a, or R507 refrigerants. At room temperatures above 34°F (1.1°C) (and evaporating temps no lower than 24 °F (-4.4°C)) positive coil defrosting (Electric or Hot Gas) is not required. (The air flowing through the coil will accomplish the defrost). At room temperatures of 34°F (1.1°C) and below, positive defrosting is required (either Electric (ED) or Hot Gas (HE, RE, TE) in model nomenclature). These models require the use of (1) Time Clock or equivalent (to initiate and terminate the defrost cycle), and (2) Defrost Termination Control (to prevent unnecessary prolonged heating and steaming of the coil once all the ice and frost has melted), (3) Hot Gas models also utilize a Fan/Heater drain pan control.

The coil must not be exposed to any abnormal atmospheric or acidic environments. This may result in corrosion to the cabinet and possible coil failure (leaks). (Consult manufacturer for optional baked on phenolic protective coatings).

LOCATION

The unit location in the room should be selected to ensure uniform air distribution throughout the entire space to be refrigerated. Be sure that the unit does not draw air in, or

blow directly out, through an opened door and that the product does not obstruct the free circulation of air. Allow a minimum of 24" clearance at each end. LV Unit Coolers draw air through the fans and discharge air through both coils.

Consideration should be given to the coil location in order to minimize the piping run length to the condensing unit and floor drain.

EXPANSION VALVE (TXV) SELECTION

All units require the use of an **externally equalized** expansion valve. (A 1/4" (6 mm) O.D. equalizer line has been provided on the coil) TX valves should **not** be selected strictly by their nominal ton rating. (This rating is based at a specific pressure differential and entering liquid temperature). Since applications will differ it is suggested the following selection procedure be followed.

1. Determine actual unit cooler BTUH or KW (thermal). The nominal rating is based at 10 °F T.D. (5.5°C) (Room Temp. minus Evap. Temp.). Note that a higher / lower operating T.D. will increase / decrease this capacity rating by their direct ratio.
2. Determine the pressure drop across the valve by subtracting the suction (evaporating) pressure from the high side liquid pressure. Note: Also subtract the distributor pressure loss (use approx. 25 psig (1.1 bar) for R134a and 35 psig (2.4 bar) for R22, R404A, R507).
3. Estimate entering liquid temperature. Temperatures lower than 100 °F (37.7 °C) increase valve capacity ratings. Refer to valve manufacturer's specs for details.
4. Select valve from the valve manufacturer selection charts for the appropriate refrigerant, evaporating temp and pressure drop.
5. After following the manufacturer's installation instructions and after the room has reached the desired temperature the valve superheat should be checked. This will confirm that the evaporator is operating properly and performing to maximum efficiency. The superheat should be around 5 (2.7°C) to 8 °F (4.4°C) for a 10 to 12 °F (5.5 to 6.6°C) T.D. Too high or low a super heat will result in unsatisfactory system performance and possible compressor problems.

NOZZLE INSTALLATION

All LV Unit Coolers have nozzles installed at factory. For nozzle selection refer to selection table. In case it is required to install the nozzle at some point in the future, the nozzle retainer clip (in distributor) must be removed before inserting nozzle. Re-install clip ensuring nozzle is properly in place.

INSTALLATION INSTRUCTIONS (cont'd)

MOUNTING

Refer to dimensional drawing for recommended mounting arrangements. Formed mounting channels are provided for flush mounting to the ceiling. Ensure adequate clearance (at least 24" (600 mm)) is provided at each end (to enable access to the electrical and refig. compartments).

Ensure that the ceiling is level since the drain pan has been sloped for drainage during the defrost cycle.

DRAIN LINE

The drain line should be run from the drain connection, sloping at least 1/4" (6 mm) per foot. A trap in a warm area outside the room will allow proper draining through the tubing. Connection should be made to proper drainage facilities that comply with local regulations.

To prevent freeze-up when the temperature of the refrigerated space is 35 °F (1.7 °C) or lower, the drain line should be heated along its run inside the cold room. The heated drain line should be insulated. It is recommended that the heater be energized at all times. A heat input of 20 watts per foot in a 28°F (-2.2°C) room, is satisfactory. Drain line heaters are not required for constant room temperature above 35°F (1.6°C).

Ensure that the drain line has sufficient slope for proper drainage (prevention of ice build up/blockage in pan).

PIPING

Refrigerant line sizes are important and **may not** be the same size as the coil connections. Consult "Recommended refrigerant line sizes" charts in any standard reference book for proper line sizing.

Refrigerant piping and control system should be designed to prevent possible liquid slugging (from oil or refrigerant) of the compressors on start-up after the defrost cycle. On Hot Gas Defrost Systems the suction accumulator should be at least 2.5 times the coils operating charge.

See Dimensional data for line locations. For Reverse Cycle and Hot Gas models and 3-Pipe - see fig. 2 & 3 respectively on page 12 for typical unit piping. These models include a check valve (unmounted) packaged along with the nozzle in the refig. connection compartment end panel.

WIRING

Wire system in accordance with governing standards and local codes. See data and wiring diagrams on pages 6 to 10 for wiring arrangement. Electrical wiring is to be sized in accordance with minimum circuit ampacity rating (MCA).

For ease of identifying the proper wiring terminal, unit wiring is color coded and terminal block connections are identified.

SYSTEM CHECK

Before Start-Up:

1. All wiring should be in accordance with local codes.
2. Refrigerant lines should be properly sized.
3. Off cycle defrost and electric defrost systems preferably must include a liquid line solenoid valve and suction accumulator.
4. Thorough evacuation and, dehydration has been performed.
5. The suction, discharge, and receiver service valves must be open.
6. The system preferably must include a liquid line drier moisture indicator and suction filter.
7. Pour enough water into the drain pan to allow a good check on drainage and seal the trap.

After Start-Up:

1. Check the oil level to be sure the oil charge is correct.
2. On initial start up the fans do not start until coil temperature is pulled down to approximately 35 °F (1.7 °C) on the hot gas coil. Also, it is normal for the fans to cycle a few times until the room temperature is pulled down.
3. Fan/Heater control and defrost termination control is factory installed for reverse cycle defrost operation. Refer to Fig. 1 on page 12.
4. If coil is to be used for 3-pipe (bypass) Hot Gas Defrost, Fan/Heater must be moved from suction line to hot gas inlet line and the defrost termination control moved to the suction line. Refer to Fig. 1 on page 12.
5. In general, evaporators running with a TD of 10 °F should have a superheat reading of 5° to 8 °F (2.7 °C to 4.4 °C). For evaporators with a higher TD, the superheat should be 8° to 12°F (4.4 °C to 6.6 °C).
6. Heavy moisture loads are usually encountered when starting the system for the first time. This will cause a rapid build-up of frost on the unit cooler. During the initial pull down, we suggest that the frost build-up be watched and defrosted manually as required. This may be done by rotating the inner dial on the timer until the pin in the outer dial is directly opposite the timer pointer. (Paragon 8145-20 Timer by others).
7. Observe that the system goes through at least one complete DEFROST CYCLE.

MAINTENANCE

The unit should be periodically inspected for any dirt or build-up on the fin surface and cleaned if necessary with a soft whisk or brush. Also ensure coils inner and outer drain pans do not have any ice build-up from improper defrost operation. When replacing heater elements first remove heater retainer brackets and heater clips.

SERVICE PARTS LIST

Motors	Models	Part Number
100V-115V PSC, 1/15HP	All	1073403
200V-230V PSC,1/15HP	All	1073405
100V-115V ECM	060, 120, 180	1086913
100V-115V ECM	090, 150, 220, 270, 300, 340, 370	1086912
200V-230V ECM	060, 120, 180	1086915
200V-230V ECM	090, 150, 220, 270, 300, 340, 370	1086914
Heaters		
Coil Face Heater, 115V, 650W	060, 090, 120, 150	1070854-003
Coil Face Heater, 115V, 930W	180, 220, 270, 300	1070854-002
Coil Face Heater, 115V, 1140W	340, 370	1070854-001
Drain Pan Heater, 115V, 290W	060, 090, 120, 150	1070854-006
Drain Pan Heater, 115V, 410W	180, 220, 270, 300	1070854-005
Drain Pan Heater, 115V, 510W	340, 370	1070854-004
Fan Blades		
14" 35° 5 Blades	090, 270, 340	1073414
14" 32° 5 Blades	150, 220, 300, 370	1073415
14" 22° 5 Blades	060, 120, 180	1073416
Fan/Heater Control	Hot Gas Defrost Models (RE & HE)	1073640
Defrost Termination	All	1071280
Fan Guard	All	1073456

NOTES

NOTES

SERVICE LOG

DATE	COMMENTS

FINISHED GOODS WARRANTY

The terms and conditions as described below in the General Warranty Policy cover all products manufactured by National Refrigeration.

GENERAL WARRANTY POLICY

Subject to the terms and conditions hereof, the Company warrants all Products, including Service Parts, manufactured by the Company to be free of defects in material or workmanship, under normal use and application for a period of one (1) year from the original date of installation, or eighteen (18) months from the date of shipment from the Company, whichever occurs first. Any replacement part(s) so supplied will be warranted for the balance of the product's original warranty. The part(s) to be replaced must be made available in exchange for the replacement part(s) and reasonable proof of the original installation date of the product must be presented in order to establish the effective date of the warranty, failing which, the effective date will be based upon the date of manufacture plus thirty (30) days. Any labour, material, refrigerant, transportation, freight or other charges incurred in connection with the performance of this warranty will be the responsibility of the owner at the current rates and prices then in effect. This warranty may be transferred to a subsequent owner of the product.

THIS WARRANTY DOES NOT COVER

(a) Damages caused by accident, abuse, negligence, misuse, riot, fire, flood, or Acts of God (b) damages caused by operating the product in a corrosive atmosphere (c) damages caused by any unauthorized alteration or repair of the system affecting the product's reliability or performance (d) damages caused by improper matching or application of the product or the product's components (e) damages caused by failing to provide routine and proper maintenance or service to the product (f) expenses incurred for the erecting, disconnecting, or dismantling the product (g) parts used in connection with normal maintenance, such as filters or belts (h) products no longer at the site of the original installation (i) products installed or operated other than in accordance with the printed instructions, with the local installation or building codes and with good trade practices (j) products lost or stolen.

No one is authorized to change this WARRANTY or to create for or on behalf of the Company any other obligation or liability in connection with the Product(s). There is no other representation, warranty or condition in any respect, expressed or implied, made by or binding upon the Company other than the above or as provided by provincial or state law and which cannot be limited or excluded by such law, nor will we be liable in any way for incidental, consequential, or special damages however caused.

The provisions of this additional written warranty are in addition to and not a modification of or subtraction from the statutory warranties and other rights and remedies provided by Federal, Provincial or State laws.

PROJECT INFORMATION

System	
Model Number	Date of Start-Up
Serial Number	Service Contractor
Refrigerant	Phone
Electrical Supply	Fax

“AS BUILT” SERVICE PARTS LIST

**Service Parts List
Label
To Be Attached
*HERE***



NATIONAL REFRIGERATION & AIR CONDITIONING CANADA CORP.
159 Roy Blvd. • Brantford • Ontario, Canada N3R 7K1
Phone (519) 751-0444 • 800-463-9517 • Fax: (519) 753-1140

