



TTW TWO-WAY UNIT COOLERS

SPECIFICATIONS INSTALLATION, OPERATION AND MAINTENANCE MANUAL

HIGH, MEDIUM AND LOW TEMPERATURE
APPLICATIONS -10 °F (-23.3 °C) ROOM
AND ABOVE

AIR OR ELECTRIC DEFROST MODELS

ELECTRICAL POWER: 115/1/60 ,
208-230/1/60, 200-220/1/50

Bulletin T30-TTW-PDI-13
1070802

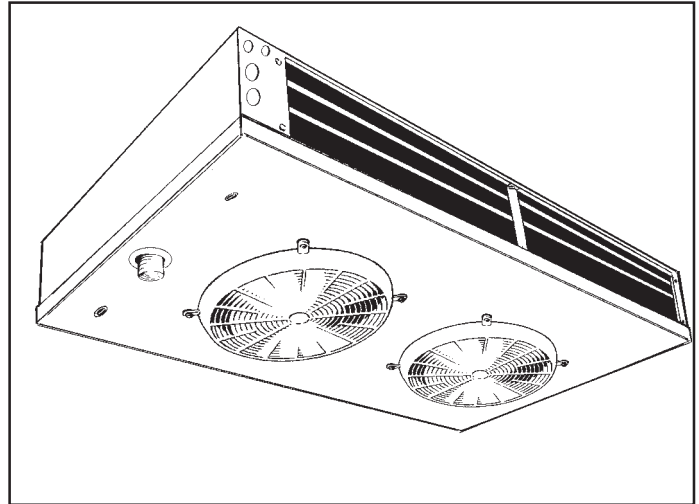

NOMENCLATURE

TTW 009 AD - S1 A

TRENTON
TWO-WAY UNIT COOLER

NOMINAL CAPACITY @ 10 °F TD
9 = 900 BTUH
AIR DEFROST (AD) RATED AT 20 °F EVAP. TEMP.
ELECTRIC DEFROST (ED) RATED AT -20 °F EVAP. TEMP.

TYPE OF DEFROST
AD = AIR DEFROST
ED = ELECTRIC DEFROST

REVISION LEVEL

ELECTRICAL DESIGNATION

S1 = 115/1/60
S2 = 208-230/1/60
S6 = 200-220/1/50

- Low height compact size maximizes useable storage space
- Dual refrigeration coils and two-way air distribution reduces air velocities to minimize product dehydration.
- Air enters through fan and discharges two ways out of each coil side.
- NEW rugged heavy duty motor mount reduces vibration and noise.
- Electric defrost models include factory installed defrost termination and fan delay thermostat.
- NSF approved "flush to ceiling mount"
- Refrigerants R134a, R22 and R404A.

CONTENTS

PAGE

General Specifications.....	2, 3
Wiring Diagrams.....	4 - 6
Dimensional Data.....	7, 8
TXV / Nozzle Selections.....	9
Installation Instructions.....	10, 11
Service Parts List.....	Back
Service Log.....	Back

WE ARE ON THE INTERNET

www.trentonrefrigeration.com

60Hz SPECIFICATIONS

60Hz Capacity Data - BTUH

Evap. Temp °F (°C)	TTW Model Number AD (Air Defrost) ED (Electric Defrost)									
	009AD	013AD	017AD	020AD	025AD	030AD	045AD	060AD	090AD	115AD
	008ED	011ED	015ED	018ED	022ED	026ED	039ED	051ED	077ED	098ED
Capacity @ 10 °F (5.6 °C) TD										
+20/+25 (-6.7/-3.9)	870	1260	1660	2030	2500	3000	4500	6000	9000	11500
+10 (-12.2)	853	1235	1627	1989	2450	2940	4410	5880	8820	11270
0 (-17.8)	827	1197	1577	1929	2375	2850	4275	5700	8550	10925
-10 (-23.3)	792	1147	1511	1847	2275	2730	4095	5460	8190	10465
-20 (-28.9)	740	1071	1411	1726	2125	2550	3825	5100	7650	9775
Capacity @ 15 °F (8.4 °C) TD										
+20/+25 (-6.7/-3.9)	1305	1890	2490	3045	3750	4500	6750	9000	13500	17250
CFM	130	180	237	270	440	440	928	807	1242	1600
Refrig. LB	0.4	0.5	0.7	0.8	0.9	1.2	1.4	2.3	3.4	4.0
Charge* KG	0.2	0.2	0.3	0.4	0.4	0.5	0.6	1.0	1.5	1.8
Unit LB.	11.6	12.6	13.7	14.7	18.9	20.0	37.8	39.9	59.9	79.8
Weight KG	5.3	5.7	6.2	6.7	8.6	9.1	17.2	18.1	27.2	36.3

* Coil at 30% full (liquid)

60Hz Electrical Data

115 v -1-60 Hz		Air Defrost and Electric Defrost Models				Electric Defrost Models			
TTW Model Number		Fan Motor(s)				Defrost Heaters			
Air Defrost	Electric	Quantity (1/25 HP ea)	Total FLA	MCA (Amps)	MOP (Amps)	Total Watts	Total Amps	MCA (Amps)	MOP (Amps)
009AD-S1A	008ED-S1A	1	1.2	1.5	15	206	1.8	2.2	15
013AD-S1A	011ED-S1A	1	1.2	1.5	15	530	4.6	5.8	15
017AD-S1A	015ED-S1A	1	1.2	1.5	15	530	4.6	5.8	15
020AD-S1A	018ED-S1A	1	1.2	1.5	15	530	4.6	5.8	15
025AD-S1A	022ED-S1A	1	1.2	1.5	15	750	6.5	8.2	15
030AD-S1A	026ED-S1A	1	1.2	1.5	15	750	6.5	8.2	15
045AD-S1A	039ED-S1A	2	2.4	2.7	15	1100	9.6	12.0	15
060AD-S1A	051ED-S1A	2	2.4	2.7	15	1540	13.4	16.8	20
090AD-S1A	077ED-S1A	3	3.6	3.9	15	2270	19.7	24.6	25
115AD-S1A	098ED-S1A	4	4.8	5.1	15	2710	23.6	29.5	30

208 / 230v-1-60 Hz		Air Defrost and Electric Defrost Models				Electric Defrost Models			
TTW Model Number		Fan Motor(s)				Defrost Heaters			
Air Defrost	Electric	Quantity (1/25 HP ea)	Total FLA	MCA (Amps)	MOP (Amps)	Total Watts	Total Amps	MCA (Amps)	MOP (Amps)
009AD-S2A	008ED-S2A	1	0.7	0.9	15	206	0.9	1.1	15
013AD-S2A	011ED-S2A	1	0.7	0.9	15	530	2.3	2.9	15
017AD-S2A	015ED-S2A	1	0.7	0.9	15	530	2.3	2.9	15
020AD-S2A	018ED-S2A	1	0.7	0.9	15	530	2.3	2.9	15
025AD-S2A	022ED-S2A	1	0.7	0.9	15	750	3.3	4.1	15
030AD-S2A	026ED-S2A	1	0.7	0.9	15	750	3.3	4.1	15
045AD-S2A	039ED-S2A	2	1.4	1.6	15	1100	4.8	6.0	15
060AD-S2A	051ED-S2A	2	1.4	1.6	15	1540	6.7	8.4	15
090AD-S2A	077ED-S2A	3	2.1	2.3	15	2270	9.9	12.4	15
115AD-S2A	098ED-S2A	4	2.8	3.0	15	2710	11.8	14.8	15

MCA = Minimum Circuit Ampacity

MOP = Maximum Overcurrent Protection

50Hz SPECIFICATIONS

50Hz Capacity Data - BTUH

Evap. Temp °F (°C)	TTW Model Number AD (Air Defrost) ED (Electric Defrost)									
	009AD	013AD	017AD	020AD	025AD	030AD	045AD	060AD	090AD	115AD
	008ED	011ED	015ED	018ED	022ED	026ED	039ED	051ED	077ED	098ED
Capacity @ 10 °F (5.6 °C) TD										
+20/+25 (-6.7/-3.9)	800	1159	1527	1868	2300	2760	4140	5520	8280	10580
+10 (-12.2)	784	1136	1497	1830	2254	2705	4057	5410	8114	10368
0 (-17.8)	760	1101	1451	1774	2185	2622	3933	5244	7866	10051
-10 (-23.3)	728	1055	1390	1700	2093	2512	3767	5023	7535	9628
-20 (-28.9)	680	985	1298	1587	1955	2346	3519	4692	7038	8993
Capacity @ 15 °F (8.4 °C) TD										
+20/+25 (-6.7/-3.9)	1201	1739	2291	2801	3450	4140	6210	8280	12420	15870
CFM	108	149	197	224	365	365	770	670	1031	1328
Refrig. LB	0.4	0.5	0.7	0.8	0.9	1.2	1.4	2.3	3.4	4.0
Charge* KG	0.2	0.2	0.3	0.4	0.4	0.5	0.6	1.0	1.5	1.8
Unit LB.	11.6	12.6	13.7	14.7	18.9	20.0	37.8	39.9	59.9	79.8
Weight KG	5.3	5.7	6.2	6.7	8.6	9.1	17.2	18.1	27.2	36.3

50Hz Electrical Data

200 / 220v-1-50 Hz		Air Defrost and Electric Defrost Models				Electric Defrost Models			
TTW Model Number		Fan Motor(s)				Defrost Heaters			
Air defrost	Electric	Quantity (1/25 HP ea)	Total FLA	MCA (Amps)	MOP (Amps)	Total Watts	Total Amps	MCA (Amps)	MOP (Amps)
009AD-S6A	008ED-S6A	1	0.7	0.9	15	188	0.9	1.1	15
013AD-S6A	011ED-S6A	1	0.7	0.9	15	485	2.2	2.8	15
017AD-S6A	015ED-S6A	1	0.7	0.9	15	485	2.2	2.8	15
020AD-S6A	018ED-S6A	1	0.7	0.9	15	485	2.2	2.8	15
025AD-S6A	022ED-S6A	1	0.7	0.9	15	686	3.1	3.9	15
030AD-S6A	026ED-S6A	1	0.7	0.9	15	686	3.1	3.9	15
045AD-S6A	039ED-S6A	2	1.4	1.6	15	1007	4.6	5.7	15
060AD-S6A	051ED-S6A	2	1.4	1.6	15	1409	6.4	8.0	15
090AD-S6A	077ED-S6A	3	2.1	2.3	15	2077	9.4	11.8	15
115AD-S6A	098ED-S6A	4	2.8	3.0	15	2480	11.3	14.1	15

MCA = Minimum Circuit Ampacity

MOP = Maximum Overcurrent Protection

WIRING DIAGRAMS

AIR DEFROST - All Voltages

WITH DEFROST TIME CLOCK

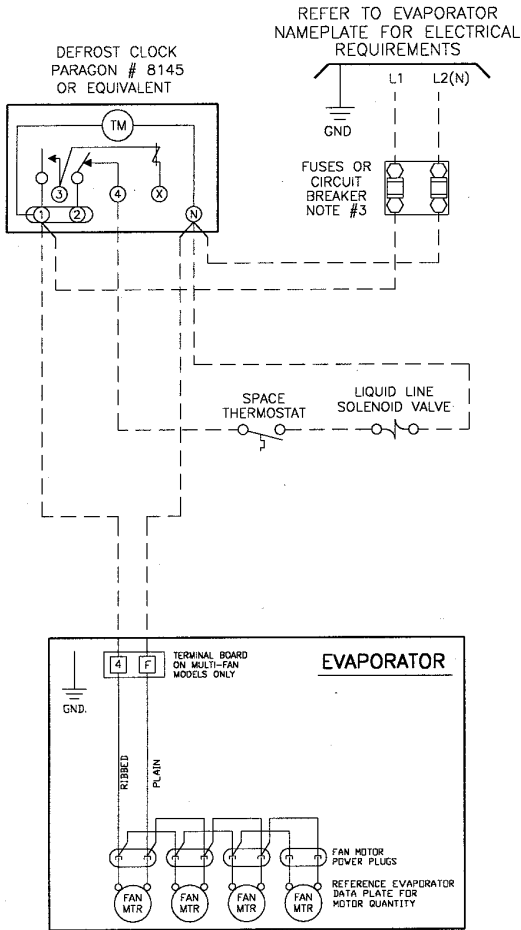

WITHOUT DEFROST TIME CLOCK

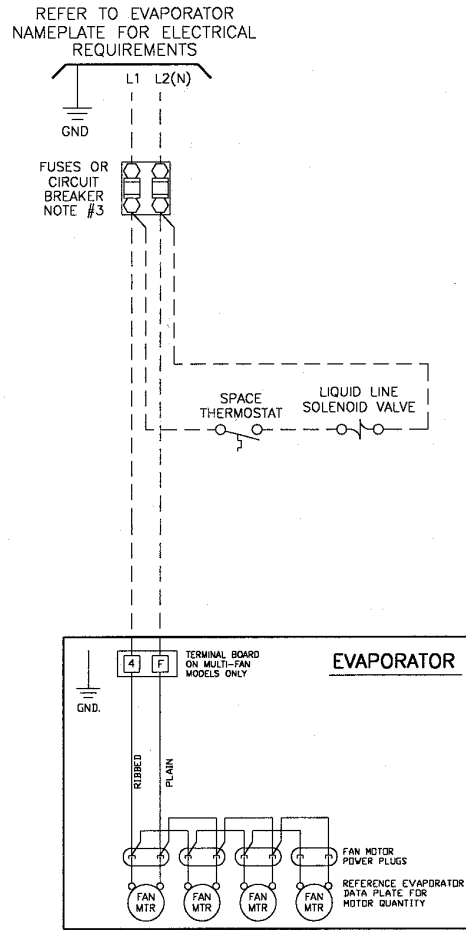

NOTES

- 1). USE COPPER CONDUCTORS ONLY
- 2). USE 60°C WIRE (OR HIGHER)
- 3). OVERCURRENT PROTECTION FOR EVAPORATOR FAN MOTORS MUST NOT EXCEED MAXIMUM VALUE SHOWN ON EVAPORATOR NAMEPLATE.

TERMINALS

- -COMPONENT TERMINAL - MARKED
- -COMPONENT TERMINAL - UNMARKED
(IDENTIFIABLE BY LOCATION)
- -COMPONENT TERMINAL - UNMARKED
(UNIDENTIFIABLE)
- -TERMINAL BLOCK TERMINAL
- -WIRE SPLICE

CONDUCTORS/WIRING

- FACTORY WIRING
- WIRING BY OTHERS

ALL FIELD WIRING MUST BE DONE IN COMPLIANCE WITH ALL APPLICABLE LOCAL AND NATIONAL CODES.

WIRING DIAGRAMS

ELECTRIC DEFROST - 115V

WITH DEFROST TIME CLOCK

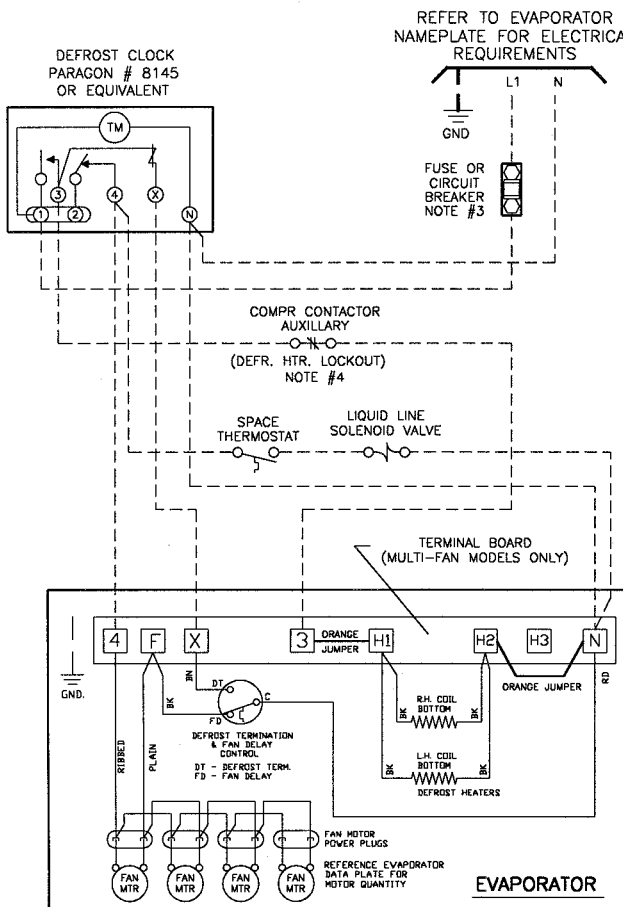

WITH DEFROST TIME CLOCK AND
DEFROST HEATER CONTACTOR

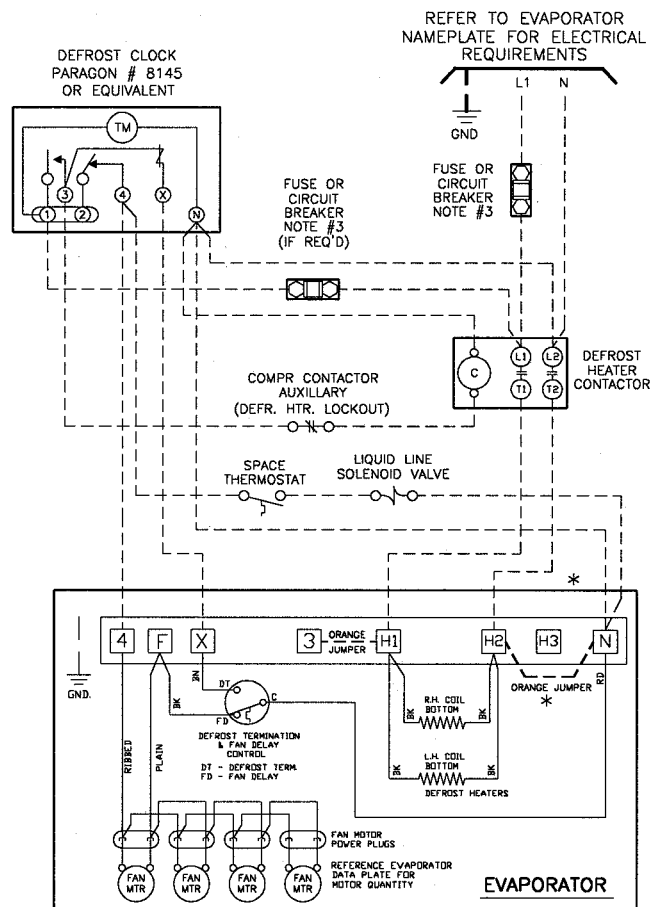

*** WARNING**
FIELD MODIFICATIONS
MUST BE MADE
WHEN DEFROST HEATER
CONTACTOR IS USED.
ORANGE JUMPER WIRE
MUST BE REMOVED
BETWEEN TERMINALS
H2 AND N

NOTES

- 1). USE COPPER CONDUCTORS ONLY
- 2). USE 60°C WIRE (OR HIGHER)
- 3). OVERCURRENT PROTECTION FOR EVAPORATOR FAN MOTORS AND DEFROST HEATERS MUST NOT EXCEED MAXIMUM VALUE SHOWN ON EVAPORATOR NAMEPLATE.
- 4). HEATER LOADS MUST NOT BE EXCEED CONTACT RATING.

TERMINALS

- -COMPONENT TERMINAL - MARKED
- -COMPONENT TERMINAL - UNMARKED (IDENTIFIABLE BY LOCATION)
- -COMPONENT TERMINAL - UNMARKED (UNIDENTIFIABLE)
- -TERMINAL BLOCK TERMINAL
- -WIRE SPLICE

CONDUCTORS/WIRING

- FACTORY WIRING
- - - - - WIRING BY OTHERS

ALL FIELD WIRING MUST BE DONE IN COMPLIANCE WITH ALL APPLICABLE LOCAL AND NATIONAL CODES.

WIRING DIAGRAMS

ELECTRIC DEFROST - 230V

WITH DEFROST TIME CLOCK

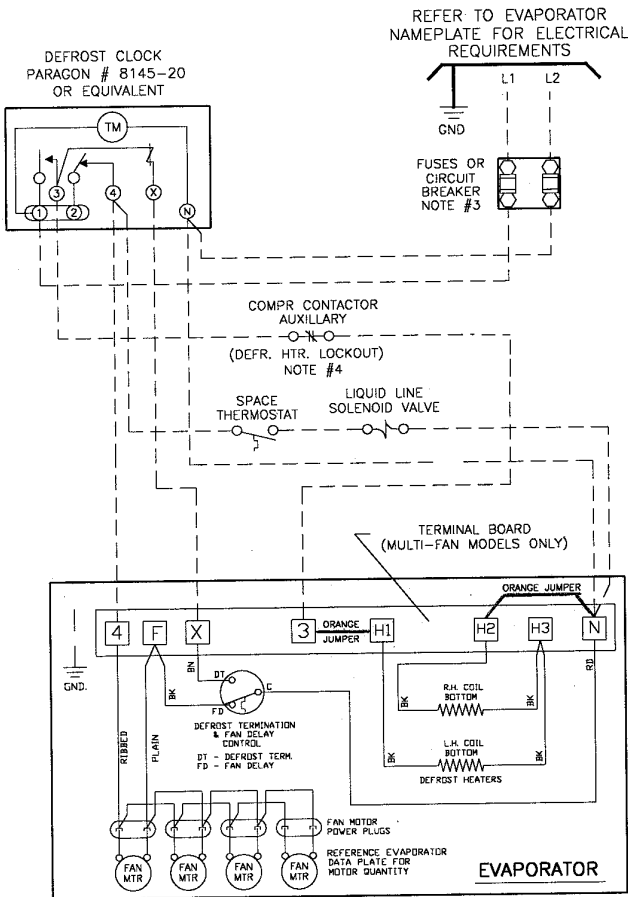

WITH DEFROST TIME CLOCK AND
DEFROST HEATER CONTACTOR

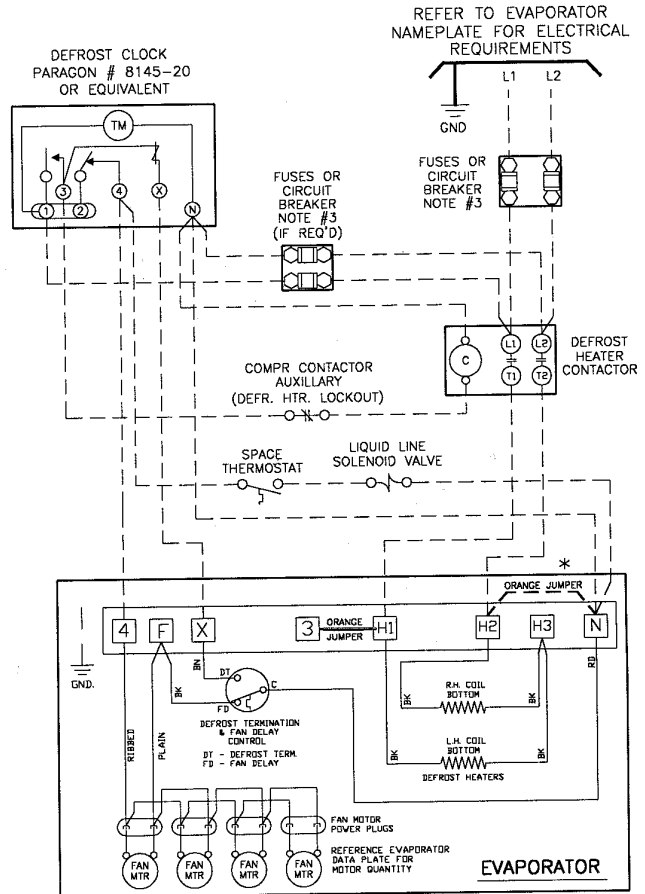

*** WARNING**
FIELD MODIFICATIONS
MUST BE MADE

WHEN DEFROST HEATER
CONTACTOR IS USED,
ORANGE JUMPER WIRE
MUST BE REMOVED
BETWEEN TERMINALS

H2 AND N

NOTES

- 1). USE COPPER CONDUCTORS ONLY
- 2). USE 60°C WIRE (OR HIGHER)
- 3). OVERCURRENT PROTECTION FOR EVAPORATOR FAN MOTORS AND DEFROST HEATERS MUST NOT EXCEED MAXIMUM VALUE SHOWN ON EVAPORATOR NAMEPLATE.
- 4). HEATER LOADS MUST NOT BE EXCEED CONTACT RATING.

TERMINALS

- - COMPONENT TERMINAL - MARKED
- - COMPONENT TERMINAL - UNMARKED
(IDENTIFIABLE BY LOCATION)
- - COMPONENT TERMINAL - UNMARKED
(UNIDENTIFIABLE)
- - TERMINAL BLOCK TERMINAL
- - WIRE SPLICE

CONDUCTORS/WIRING

- FACTORY WIRING
- - - - - WIRING BY OTHERS

ALL FIELD WIRING MUST BE DONE IN COMPLIANCE WITH ALL APPLICABLE LOCAL AND NATIONAL CODES.

DIMENSIONAL DATA

SINGLE FAN MODELS

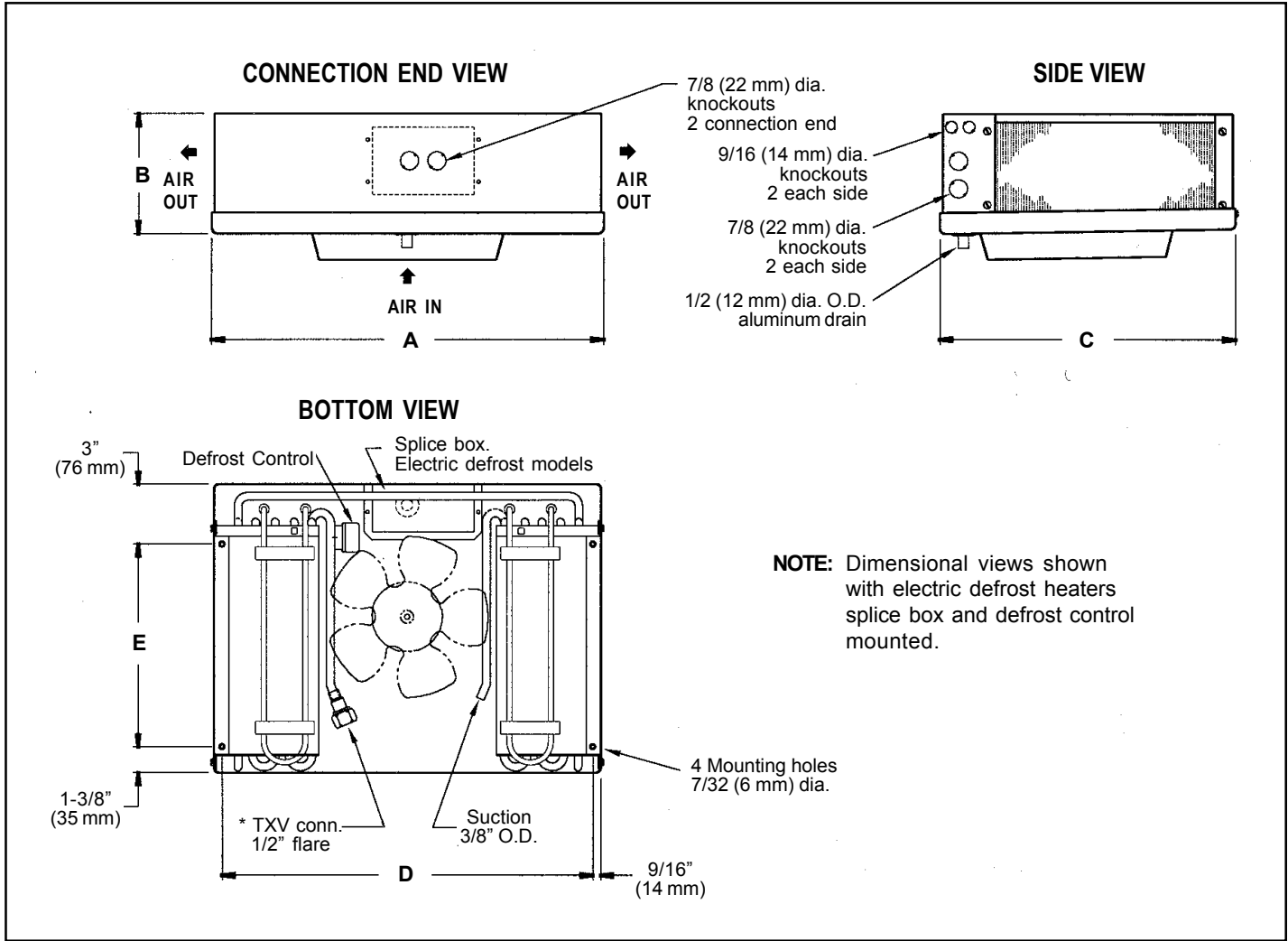

MODEL: AD/ED	DIMENSIONAL DATA - INCHES (MM)				
	A	B	C	D	E
TTW 009/008	18 7/8 (479)	4 1/2 (114)	14 1/8 (359)	17 3/4 (451)	9 3/4 (248)
TTW 013/011	18 7/8 (479)	4 1/2 (114)	14 1/8 (359)	17 3/4 (451)	9 3/4 (248)
TTW 017/015	18 7/8 (479)	5 1/2 (140)	14 1/8 (359)	17 3/4 (451)	9 3/4 (248)
TTW 020/018	18 7/8 (479)	5 1/2 (140)	14 1/8 (359)	17 3/4 (451)	9 3/4 (248)
TTW 025/022	21 7/8 (555)	5 1/2 (140)	19 1/8 (486)	20 3/4 (527)	14 3/4 (375)
TTW 030/026	21 7/8 (555)	5 1/2 (140)	19 1/8 (486)	20 3/4 (527)	14 3/4 (375)

* TXV Connection on TTW 026 ED only is 1/2" O.D.S.

DIMENSIONAL DATA

MULTIPLE FAN MODELS

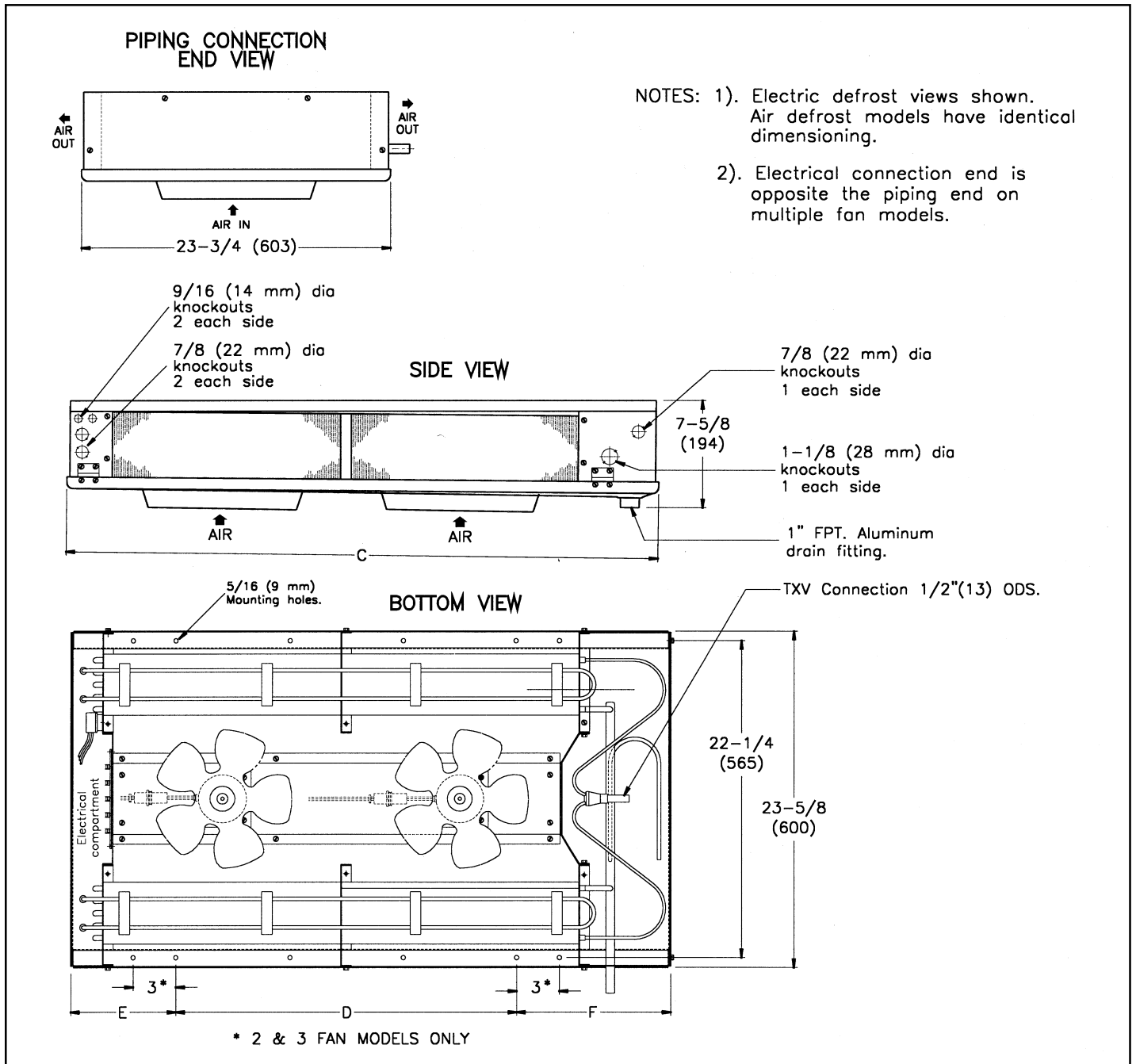

MODEL: AD/ED	No. of Fans	DIMENSIONAL DATA - INCHES (MM)				
		Suction Conn.	C	D	E	F
TTW 045/039	2	1/2" OD. (13)	42 3/4 (1086)	4 holes @ 8" (203)	7 11/16 (195)	10 15/16 (278)
TTW 060/051	2	5/8" OD. (16)	42 3/4 (1086)	4 holes @ 8" (203)	7 11/16 (195)	10 15/16 (278)
TTW 090/077	3	5/8" OD. (16)	59 1/2 (1511)	6 holes @ 8" (203)	8 (203)	11 7/16 (291)
TTW 115/098	4	7/8" OD. (22)	69 1/4 (1759)	8 holes @ 8" (203)	4 5/8 (117)	8 5/8 (219)

TXV / NOZZLE SELECTIONS - 60Hz

All models require the use of a TXV (thermostatic expansion valve). These should be mounted within the cabinet at the flare nut connection or distributor stub (all 026 ED and higher models). An internally equalized TXV can be used on any of the single fan AD models and 022 ED and smaller electric defrost models. All other models must use an externally equalized TXV. (a 1/4" OD equalizing tube is provided). All models using a distributor require a nozzle. Air Defrost models have the nozzle already FACTORY installed. Electric defrost models 026ED and larger have TWO distributor nozzles SHIPPED LOOSE and the correct selection must be made and installed prior to mounting the TXV. Refer to the following charts for nozzle / TXV selections.

NOZZLE SELECTIONS

Air Defrost Nozzles (already factory installed)

For all applications and refrigerants

Model	Nozzle
045AD	L-1/2
060AD	L-3/4
090AD	L-1
115AD	L-1 1/2

Electric Defrost Nozzles (for field installation)

For -20°F to +25 °F Evap. Temps., 8-12°F TD

Model	Nozzle	
	R22	R404A
026ED	L-1/4 *	L-1/3
039ED	L-1/3	L-1/2
051ED	L-1/2	L-3/4
077ED	L-3/4	L-1
098ED	L-1	L-1 1/2

* Use L-1/16 if lower than 9°F T.D.

SPORLAN TXV SELECTIONS

Air Defrost (35 °F and up Room Temperatures)

Model	10 °F TD				15° F TD			
	Btuh	R12 / R134a	R22	R404A/ R502	Btuh	R12 / R134a	R22	R404A/ R502
009AD	870	GJ-1/8 C	GV-1/5 C	GS-1/8 C	1305	GJ-1/8 C	GV-1/5 C	GS-1/8 C
013AD	1260	GJ-1/8 C	GV-1/5 C	GS-1/8 C	1890	GJ-1/4 C	GV-1/5 C	GS-1/8 C
017AD	1660	GJ-1/8 C	GV-1/5 C	GS-1/8 C	2490	GJ-1/4 C	GV-1/5 C	GS-1/8 C
020AD	2030	GJ-1/8 C	GV-1/5 C	GS-1/8 C	3045	GJ-1/4 C	GV-1/5 C	GS-1/4 C
025AD	2500	GJ-1/4 C	GV-1/5 C	GS-1/4 C	3750	GJ-1/4 C	GV-1/3 C	GS-1/4 C
030AD	3000	GJ-1/4 C	GV-1/5 C	GS-1/4 C	4500	GJ-1/2 C	GV-1/3 C	GS-1/4 C
045AD	4500	EGJE-1/2 C	EGVE-1/2 C	EGSE-1/2 C	6750	EGJE-1/2	EGVE-3/4 C	EGSE-1/2 C
060AD	6000	EGJE-1/2 C	EGVE-3/4 C	EGSE-1/2 C	9000	EGJE-1 C	EGVE-1 C	EGSE-1 C
090AD	9000	EGJE-1 C	EGVE-1 C	EGSE-1 C	13500	EGJE-1 C	EGVE-1 1/2 C	EGSE-1 C
115AD	11500	EGJE-1 C	EGVE-1C	EGSE-1 C	17250	EGJE-1 1/2 C	EGVE-1 1/2 C	EGSE-1 1/2 C

Note: Based on 100 °F Liquid Temperature

R22 Electric Defrost (34 °F and below Room Temperatures) 10 °F TD

Model / Evap Temp.	008ED		011ED		015ED		018ED		022ED	
	Btuh	Valve #	Btuh	Valve #	Btuh	Valve #	Btuh	Valve #	Btuh	Valve #
+20/+25 °F	870	GV-1/5 VC	1260	GV-1/5 VC	1660	GV-1/5 VC	2030	GV-1/5 VC	2500	GV-1/5 VC
+10 °F	853	GV-1/5 VC	1235	GV-1/5 VC	1627	GV-1/5 VC	1989	GV-1/5 VC	2450	GV-1/5 VC
0 °F	827	GV-1/5 VC	1197	GV-1/5 VC	1577	GV-1/5 VC	1929	GV-1/5 VC	2375	GV-1/5 VC
-10 °F	792	GV-1/5 VZ	1147	GV-1/5 VZ	1511	GV-1/5 VZ	1847	GV-1/5 VZ	2275	GV-1/5 VZ
-20 °F	740	GV-1/5 VZ	1071	GV-1/5 VZ	1411	GV-1/5 VZ	1726	GV-1/5 VZ	2125	GV-1/5 VZ

Model / Evap Temp.	026ED		039ED		051ED		077ED		098ED	
	Btuh	Valve #	Btuh	Valve #	Btuh	Valve #	Btuh	Valve #	Btuh	Valve #
+20/+25 °F	3000	EGVE-1/5 VC	4500	EGVE-1/3 VC	6000	EGVE-1/2 VC	9000	EGVE-3/4 VC	11500	EGVE-3/4 VC
+10 °F	2940	EGVE-1/5 VC	4410	EGVE-1/3 VC	5880	EGVE-1/2 VC	8820	EGVE-3/4 VC	11270	EGVE-3/4 VC
0 °F	2850	EGVE-1/3 VC	4275	EGVE-1/3 VC	5700	EGVE-1/2 VC	8550	EGVE-3/4 VC	10925	EGVE-1 VZ
-10 °F	2730	EGVE-1/3 VZ	4095	EGVE-1/2 VZ	5460	EGVE-3/4 VZ	8190	EGVE-3/4 VZ	10465	EGVE-1 VZ
-20 °F	2550	EGVE-1/3 VZ	3825	EGVE-1/2 VZ	5100	EGVE-3/4 VZ	7650	EGVE-3/4 VZ	9775	EGVE-1 VZ

Note: Based on 95 °F Liquid Temperature for -20 °F / -10 °F Evap. Temps. and 100 °F Liquid for 0 to +25 °F Evap. Temps.

R404A Electric Defrost (34 °F and below Room Temperatures) 10 °F TD

Model / Evap Temp.	008ED		011ED		015ED		018ED		022ED	
	Btuh	Valve #	Btuh	Valve #	Btuh	Valve #	Btuh	Valve #	Btuh	Valve #
+20/+25 °F	870	GS-1/8 SC	1260	GS-1/8 SC	1660	GS-1/8 SC	2030	GS-1/8 SC	2500	GS-1/8 SC
+10 °F	853	GS-1/8 SC	1235	GS-1/8 SC	1627	GS-1/8 SC	1989	GS-1/8 SC	2450	GS-1/8 SC
0 °F	827	GS-1/8 SC	1197	GS-1/8 SC	1577	GS-1/8 SC	1929	GS-1/8 SC	2375	GS-1/8 SC
-10 °F	792	GS-1/8 SZ	1147	GS-1/8 SZ	1511	GS-1/8 SZ	1847	GS-1/8 SZ	2275	GS-1/8 SZ
-20 °F	740	GS-1/8 SZ	1071	GS-1/8 SZ	1411	GS-1/8 SZ	1726	GS-1/8 SZ	2125	GS-1/8 SZ

Model / Evap Temp.	026ED		039ED		051ED		077ED		098ED	
	Btuh	Valve #	Btuh	Valve #	Btuh	Valve #	Btuh	Valve #	Btuh	Valve #
+20/+25 °F	3000	EGSE-1/6 SC	4500	EGSE-1/4 SC	6000	EGSE-1/2 SC	9000	EGSE-1/2 SC	11500	EGSE-1 SC
+10 °F	2940	EGSE-1/6 SC	4410	EGSE-1/4 SC	5880	EGSE-1/2 SC	8820	EGSE-1/2 SC	11270	EGSE-1 SC
0 °F	2850	EGSE-1/6 SC	4275	EGSE-1/4 SC	5700	EGSE-1/2 SC	8550	EGSE-1/2 SC	10925	EGSE-1 SC
-10 °F	2730	EGSE-1/6 SZ	4095	EGSE-1/4 SZ	5460	EGSE-1/2 SZ	8190	EGSE-1/2 SZ	10465	EGSE-1 SZ
-20 °F	2550	EGSE-1/6 SZ	3825	EGSE-1/2 SZ	5100	EGSE-1/2 SZ	7650	EGSE-1 SZ	9775	EGSE-1 SZ

Note: Based on 95 °F Liquid Temperature for -20 °F / -10 °F Evap. Temps. and 100 °F Liquid for 0 to +25 °F Evap. Temps.

INSTALLATION INSTRUCTIONS

INSPECTION

Careful inspection of all parts when received for loss or damage in transit is very important - Remember, you, the consignee, must make any claim necessary against the transportation company. Shipping damage or missing parts, when discovered at the outset, will prevent later unnecessary and costly delays.

Electrical characteristics should also be checked at this time to ensure that they are as ordered.

APPLICATION

Two-Way Unit Coolers are designed for use in coolers and freezers such as reach in boxes, display cases, back bars, walk-in rooms and any other cooler applications where a low velocity, uniform air flow is required. The compact and low height unit provides maximum useable product storage space.

At room temperatures above 34 °F (1.1 °C) and evaporating temperatures no lower than 27 °F (-2.8 °C) the air flowing through the coil will accomplish the defrost (Air Defrost).

At room temperatures 34 °F and below (to -10 °F) positive defrosting is required (Electric defrost) . These will require the use of :

1. *Time Clock* (to initiate and terminate the defrost cycle),
2. *Defrost termination thermostat* (to prevent unnecessary prolonged heating and steaming of the coil once all the frost and ice has melted). And if a freezer,
3. *Fan delay thermostat* (to prevent evaporator fans starting up right away and blowing water on to the fan blades, guards and floor).

This evaporator coil must not be exposed to any abnormal environments (acidic or caustic) that can result in coil corrosion and leaks. Consult factory for optional baked on phenolic protective coatings. These unit coolers are for use primarily on R134a, R22 and R404A refrigerants and their approved alternatives / replacements.

INSTALLATION

The installation and start up of Unit Coolers should only be performed by qualified refrigeration mechanics. This equipment should be installed in accordance with all applicable codes, ordinances, and local by-laws.

LOCATION

The Unit Cooler is designed to be mounted to the ceiling of the box or cabinet. Refrigeration piping and electrical connections are routed to the rear sides (through the knock-outs). The unit must be mounted to a level ceiling to ensure complete drainage from the condensate pan to the drain fitting. Refer to the dimensional drawings for the drain fitting and mounting location details.

On freezer applications it is important that warm, humid infiltrated air is ***not drawn directly towards the unit cooler***. Keeping the unit cooler away from the door, using strip curtains, and using door switches to lock out and de-energize the liquid solenoid valve are all effective methods to minimize any unnecessary frost build -up of the fan guard. (Air enters the fan and discharges out each side of the coil).

TXV (thermostatic expansion valve) SELECTION

For normal operating conditions refer to the TXV selection chart on P. 9. When selecting valves ensure they are sized to meet the capacity at the actual evaporating temperature, liquid temperature and operating TD of the system . All these conditions can greatly affect the size and selection. Consult the factory or valve manufacturer for assistance. All models that use a distributor (larger models) must use a nozzle. Smaller models do not have distributors or nozzles.

Electric defrost models 026ED and higher require ***a nozzle to be selected and field installed*** before mounting the TXV. Refer to P.9 for details. Air defrost models 045AD and higher already have the ***nozzle factory installed***.

INSTALLATION INSTRUCTIONS

The TXV superheat setting should NOT be initially adjusted . After the room has reached or is close to the required operating temperature the TXV superheat should then be checked and only adjusted if necessary. Refer to Section on SYSTEM CHECK.

To avoid overheating the valve or distributor wrap a wet cloth around the valve diaphragm and body.

MOUNTING

Mounting brackets with 7/32 - 5/16" diameter holes are provided for flush mounting to the ceiling. For details refer to the dimensional data on P.7 and 8. Ensure the evaporator is located correctly with the air flowing in the two desired directions. Avoid discharging the air directly on to glass doors or door openings.

After mounting the coil ***check the slope*** of the drain pan with a level. If the ceiling is not level the drain pan slope may not be correct which can result in defrosting (ice-up) problems.

DRAIN LINE

The drain line should be run from the drain connection, sloping at least 4" vertical drop for every foot of horizontal distance . A trap outside the room will allow proper draining throughout the line. Connection should be made to proper drainage facilities that comply with local codes and regulations.

In freezers, to prevent drain line freeze up problems, the line must be heated and insulated. A heat input of 20 W per foot in a 0 °F room and 30 W per foot in a -20 °F room is usually satisfactory. Once the line has been completed , double check the slope in the drain pan to ensure proper drainage (prevention of ice build-up on pan).

PIPING

Refrigerant line sizes are important and are not necessarily the same size as the connections at the condensing unit or evaporator. If in doubt refer to a recognized source. (Manufacturer's Engineering Manual, Ashrae Manuals, etc.)

WIRING

Wire system in accordance with local codes and regulations. A 36" cord is provided for single fan air defrost models (AD) .Multiple fans have a junction terminal box for conduit connections. See electrical data and wiring diagrams on P. 2 - 6.

When Fan delay thermostats are installed the fans may not start up until the coil temperature reaches approximately 26 °F . On initial start up it may be necessary to bypass (jumper) this control temporarily until the coil is cold enough.

SYSTEM CHECK

Before Start Up:

1. Ensure wiring is in accordance with codes.
2. Refrigerant lines are properly sized and routed.
3. Thorough leak check, evacuation and dehydration has been performed.
4. Drain line has been checked for free flow.

After Start Up:

1. Fan has been checked for correct air flow and no obstructions.
2. Expansion valve superheat has been checked for proper operation. (Superheat of the coil should be around 5 to 6 °F for a 10 °F TD.)

MAINTENANCE

The unit should be periodically inspected for any dirt or build up on the fin surface and cleaned if necessary with a soft whisk or brush. The fan motor is permanently lubricated and should not require service.

SERVICE PARTS LIST

MODEL NUMBER		FAN MOTOR		FAN BLADE	FAN GUARD	DEFROST HEATERS*	DRAIN PAN
AIR	ELECTRIC	115/1/60	208-230/1/60			(ED models only)	
TTW009AD	TTW008ED	1069592	1069593	1043870-001	1043293	1070468-001	1043868-001
TTW013AD	TTW011ED	1069592	1069593	1043870-002	1043293	1069861-001	1043868-001
TTW017AD	TTW015ED	1069592	1069593	1043870-003	1043293	1069861-001	1043868-001
TTW020AD	TTW018ED	1069592	1069593	1043870-004	1043293	1069861-001	1043868-001
TTW025AD	TTW022ED	1069592	1069593	1043870-005	1043294	1069861-002	1043869-001
TTW030AD	TTW026ED	1069592	1069593	1043870-005	1043294	1069861-002	1043869-001
TTW045AD	TTW039ED	1069592	1069593	1043870-005	1043294	1070468-002	1070010-001
TTW060AD	TTW051ED	1069592	1069593	1043870-005	1043294	1069861-003	1070010-001
TTW090AD	TTW077ED	1069592	1069593	1043870-006	1043294	1069861-004	1070011-001
TTW115AD	TTW098ED	1069592	1069593	1043870-006	1043294	1069861-005	1070012-001
Air Defrost (045 and up) Terminal Board - 1048825							
Electric Defrost (039 and up) Terminal Board - 1070060							
Electric Defrost Fan Delay / Defrost Termination Control - 1043725							

* All heaters are rated at 115V - either wired in series (for 230V) or parallel (for 115V)

SERVICE LOG

DATE	COMMENTS

PROJECT INFORMATION

System	
Model Number	Date of Start-Up
Serial Number	Service Contractor
Refrigerant	Phone
Electrical Supply	Fax



NATIONAL REFRIGERATION & AIR CONDITIONING CANADA CORP.
159 Roy Blvd. • Brantford • Ontario, Canada N3R 7K1
Phone (519) 751-0444 • 800-463-9517 • Fax: (519) 753-1140



Due to National Refrigeration's policy of continuous product improvement, we reserve the right to make changes without notice.