

NATIONAL REFRIGERATION

PROGRAM SPECIFICATIONS AND OPERATING INSTRUCTIONS

1085509

SmartVapII™ Defrost Control System

Model: 1083700

Electrical Power: 115/1/60 - Air Defrost,
208-230/1/60 - Air & Electric Defrost
200-220/1/50 - Air & Electric Defrost

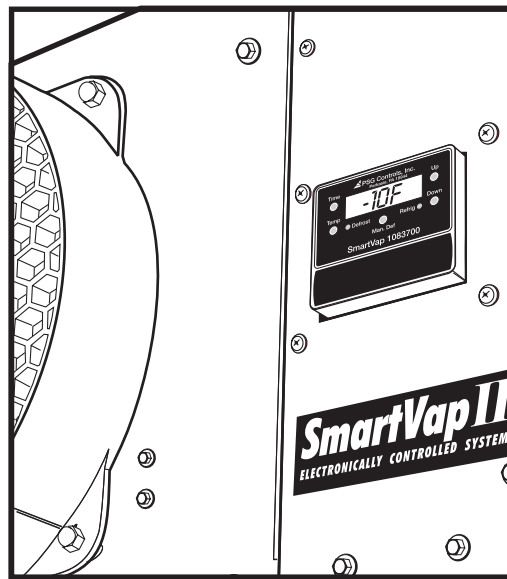

FEATURES:

- For use with 230V Single Phase Electric Defrost Evaporators
 - Simple field hook up –Two Pipes-Two Wires –It's Done
- No wiring required to condensing unit / No field adjustments /set up
- Thermostat and defrost controls all factory set (-10°F freezer/ +39°F cooler)
 - Simple user-friendly adjustments/ programming (if required)
- Available for Air Defrost (120 or 230V) +35°F Room and up applications
 - User Lock Option (prevents unauthorized control adjustments)

CONTENTS

Operating Instructions	2 - 3
Wiring Diagrams	4 - 6
Troubleshooting Guide.....	7 - 8

OPERATING INSTRUCTIONS

Electric Defrost Factory Settings:

The following are the factory default settings and will suit most applications:

- Room Thermostat Cut-In Set Point :
-10°F for Freezer, and +39°F for cooler
- Defrost Frequency: 4 cycles per day with maximum fail safe of 35 minutes.
- Defrost Termination set point : 55°F
- Fan Delay time set point: 3 minutes.
- User adjustments unlocked.



LED Display Indicators:

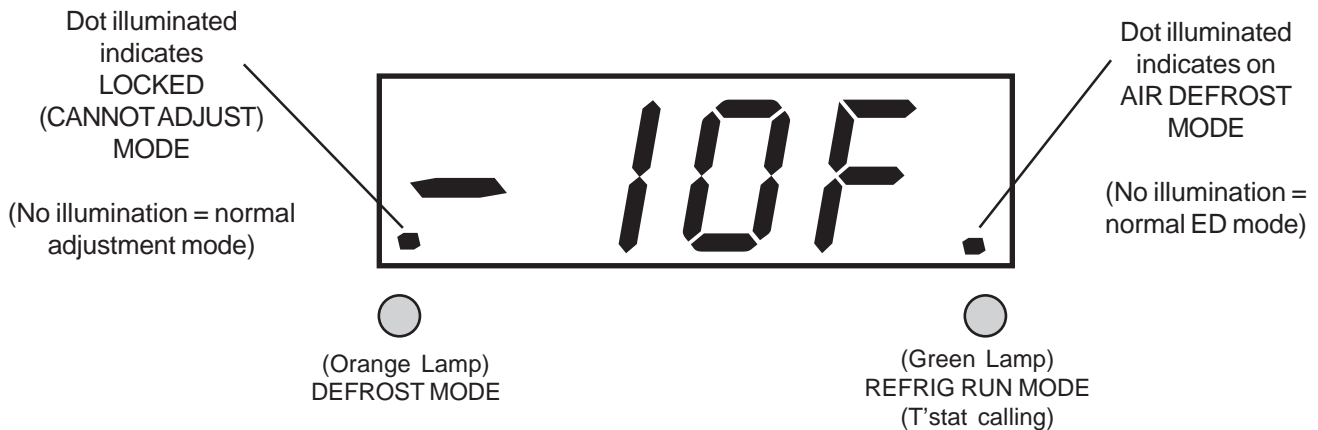

“Time” Button Functions

To view any of the “Time” button settings, just press and release in the following order.
To adjust settings, hold down “Time” button, while pushing “Up” or “Down” buttons.

Function	Display Shows:	Adjustment Range:	Factory Default Setting:
CLOCK actual time	“23:59”	00:00 to 23:59	12:00
DEFROSTS per day	“nd04”	nd01 to nd12	nd04
FIRST DEFROST time	“dEF01 / 9:00”	00:00 to 23:59	9:00
MAX DEFROST Duration Time	“dEFd / 35”	15 mins* to 2 hours	35 mins
FAN DELAY	“Fd-03”	01 to 06** minutes	03 mins

* Defrost cycle has a minimum 15 minute duration (unless reaches 75°F on evaporator)

** CAUTION: long delay times can cause refrigerant flood back to the compressor

“Temp” Button Functions

To view any of the “Temp” button settings, just press and release in the following order.
To adjust settings, hold down the “Temp” button while pushing “Up” or “Down” buttons.

Function	Display Shows:	Adjustment Range:	Factory Default Setting:
ROOM SET POINT cut-in temp.	“SP / -10F”	-40 to 99°F	-10°F (Freezer) +39°F (Cooler)
ROOM set point differential	“diF / 04F”	2 to 25°F	4°F
EVAP end plate temperature	“EVAP” / actual °F	NA (reading only)	NA
DEFROST termination temp.	“dt° / 55°F”	40 to 70°F	55°F
F-C Fahrenheit/Celsius	“F”	F or C	F

“Man. Def” (Manual Defrost) Button Function

Push and hold down (1 sec) to activate a manual defrost cycle. To cancel at any time just push again (hold for 1 sec). All regular timed defrosts will still continue to be scheduled.

The defrost will not start if the evap end plate is over 55°F (set point of termination temp). During any defrost cycle the display will indicate the room set point setting and will not display the actual room temperature until 4 minutes after the defrost has terminated.

User Lock Option

To prevent unauthorized personnel from tampering with any settings, a locking function can be enabled. This will allow any user to view the settings but will prevent anyone from making adjustments. The LED display will indicate LOC for 4 seconds during any attempt to adjust.

To activate the lock mode, hold down the “Temp”, “Up” and “Down” buttons together for three seconds.

To de-activate, wait for LOC (if displayed) to clear from display, then follow the same procedure as programming the lock mode.

Note: the display will have a LED dot indicator on the display when in locked mode (see “LED Display” section)

Loss of Power

All previously programmed set points will be retained in the program during the event of a power loss. The clock time will re-start at the time setting of when the power was lost (similar to mechanical defrost clock) .

Air Defrost Application:

Ensure wiring has been modified according to the air defrost diagram. Fans must stay on all the time. For air defrost applications the room temperature should be no colder than 35°F.

To program the control to Air Defrost mode push the “UP” and “DOWN” button together. After 5 seconds “Ed” will appear in the display (continue holding down buttons) after 5 more seconds “Ad” will appear in the display at this point release both buttons. A small LED dot will appear in the bottom right hand corner of the display, indicating the control is now programmed for air defrost mode. Factory settings are: Room thermostat cut-in: 39°F. Defrost frequency: 3 cycles per day for 45 minute duration.

Troubleshooting Guide:

see pages 7 & 8.

Technical Assistance:

contact the factory at 1-800-463-9517

WIRING DIAGRAM - LESS THAN 12A

SMARTVAP EVAPORATOR LOW PROFILE 12A MAX ELECTRIC DEFROST

USING MAX 15A HEATER OVERCURRENT PROTECTION
REFER TO EVAPORATOR NAMEPLATE FOR ELECTRICAL REQUIREMENTS

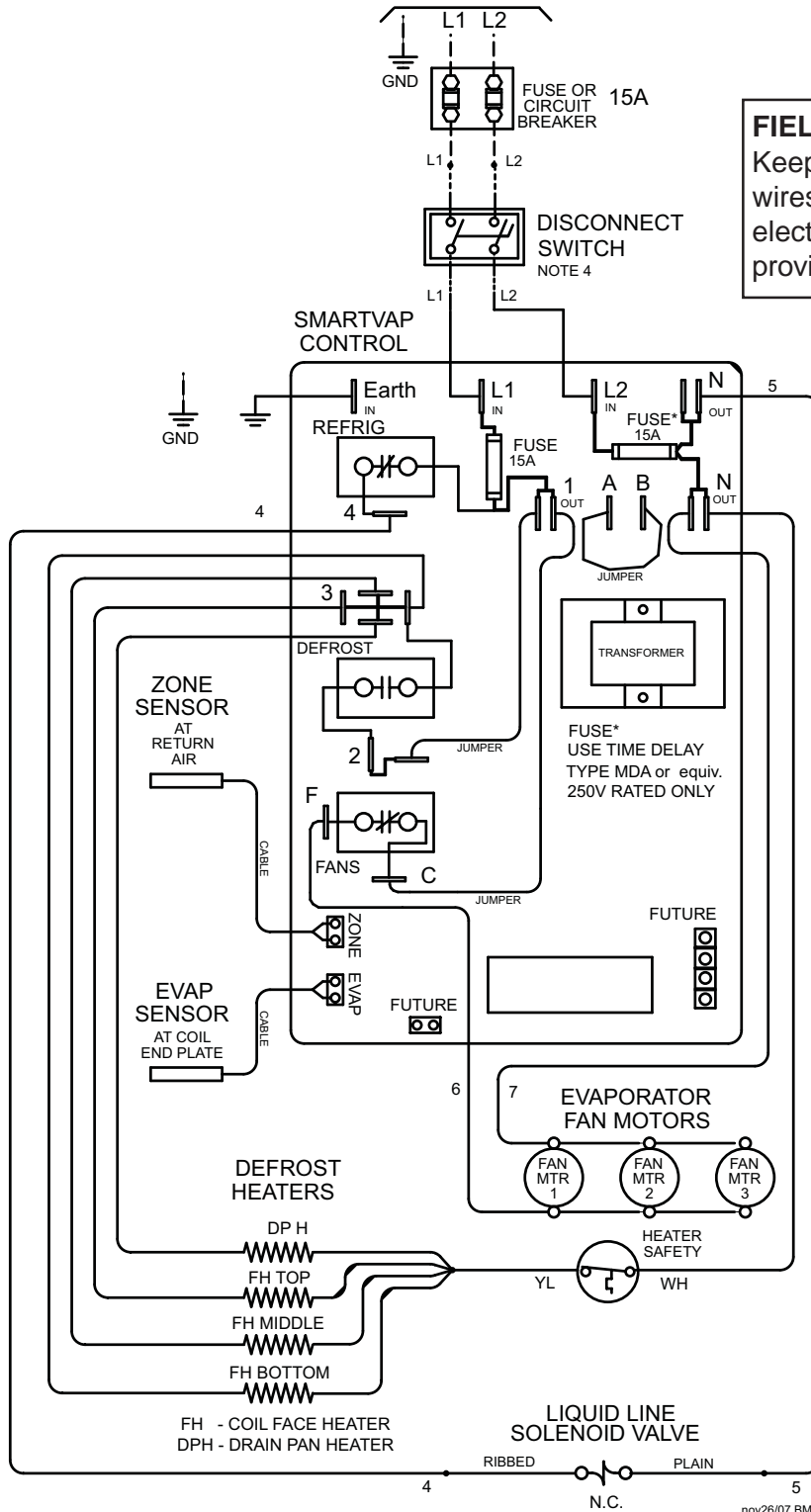

FIELD POWER NOTE:
Keep all incoming field power wires away from microprocessor / electronic area. Use shielded area provided.

- NOTES**
- 1). USE COPPER CONDUCTORS ONLY
 - 2). USE 75°C WIRE (OR HIGHER)
 - 3). OVERCURRENT PROTECTION FOR EVAPORATOR FAN MOTORS AND DEFROST HEATERS MUST NOT EXCEED MAXIMUM VALUE SHOWN ON EVAPORATOR NAMEPLATE.
 - 4.) MAY BE FACTORY INSTALLED-MOUNTED AND WIRED ON EVAPORATOR

TERMINALS

- -COMPONENT TERMINAL
- -TERMINAL BLOCK TERMINAL

CONDUCTORS/WIRING

- FACTORY WIRING
- - - - - WIRING BY OTHERS
- · · · · OPTIONAL FACTORY OR BY OTHERS

ALL FIELD WIRING MUST BE DONE IN COMPLIANCE WITH ALL APPLICABLE LOCAL AND NATIONAL CODES.

REVISIONS		DIAGRAM NUMBER
DATE	LTR	1084655
-	-	

WIRING DIAGRAM - OVER 12A

SMARTVAP EVAPORATOR LOW PROFILE >12A ELECTRIC DEFROST

REFER TO EVAPORATOR NAMEPLATE FOR ELECTRICAL REQUIREMENTS

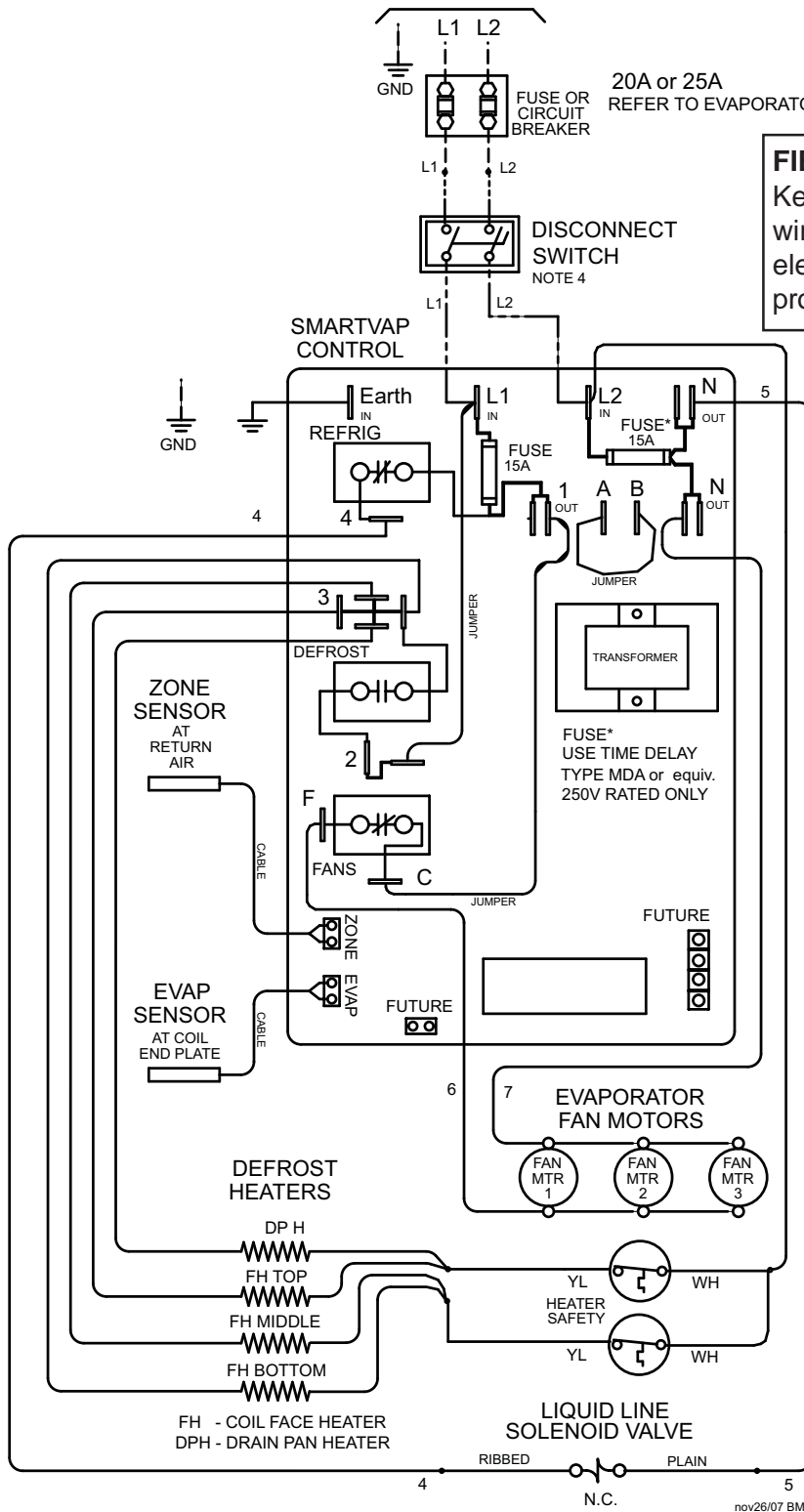

FIELD POWER NOTE:
Keep all incoming field power wires away from microprocessor / electronic area. Use shielded area provided.

- NOTES**
- 1). USE COPPER CONDUCTORS ONLY
 - 2). USE 75°C WIRE (OR HIGHER)
 - 3). OVERCURRENT PROTECTION FOR EVAPORATOR FAN MOTORS AND DEFROST HEATERS MUST NOT EXCEED MAXIMUM VALUE SHOWN ON EVAPORATOR NAMEPLATE.
 - 4.) MAY BE FACTORY INSTALLED-MOUNTED AND WIRED ON EVAPORATOR

TERMINALS

- -COMPONENT TERMINAL
- -TERMINAL BLOCK TERMINAL

CONDUCTORS/WIRING

- FACTORY WIRING
- - - - - WIRING BY OTHERS
- OPTIONAL FACTORY OR BY OTHERS

ALL FIELD WIRING MUST BE DONE IN COMPLIANCE WITH ALL APPLICABLE LOCAL AND NATIONAL CODES.

REVISIONS		DIAGRAM NUMBER
DATE	LTR	1084655>12A
-	-	

WIRING DIAGRAM - AIR DEFROST - 12A MAX.

SMARTVAP EVAPORATOR

LOW PROFILE 12A MAX AIR DEFROST

REFER TO EVAPORATOR NAMEPLATE FOR ELECTRICAL REQUIREMENTS

FIELD POWER NOTE:

Keep all incoming field power wires away from microprocessor / electronic area. Use shielded area provided.

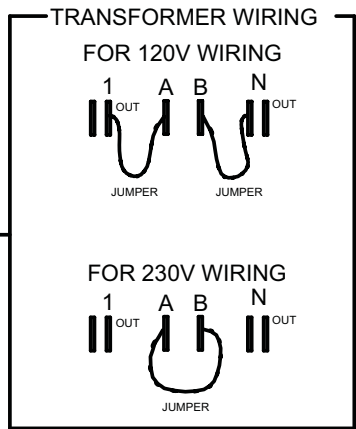
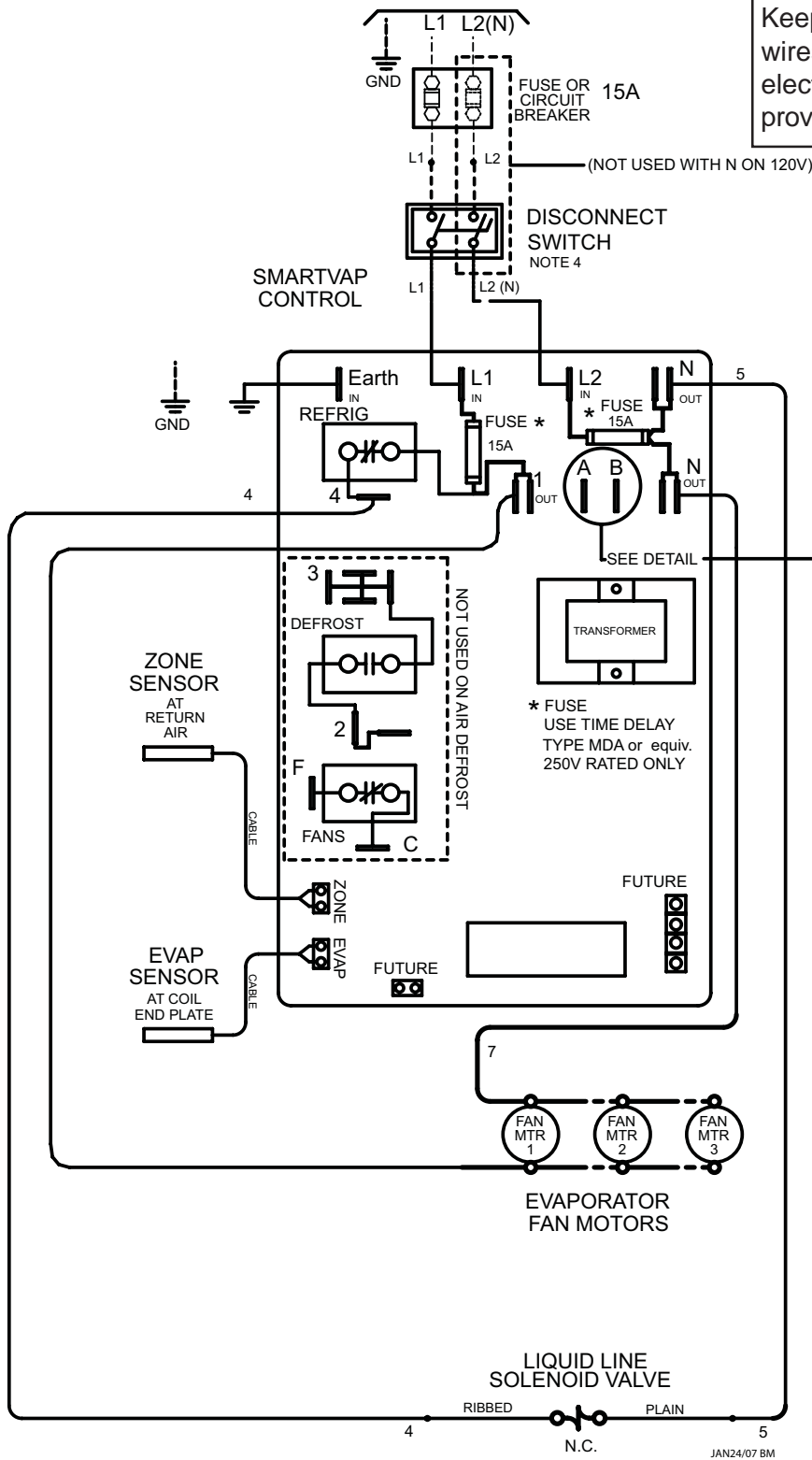

NOTES

- 1). USE COPPER CONDUCTORS ONLY
- 2). USE 75°C WIRE (OR HIGHER)
- 3). OVERCURRENT PROTECTION FOR EVAPORATOR FAN MOTORS AND DEFROST HEATERS MUST NOT EXCEED MAXIMUM VALUE SHOWN ON EVAPORATOR NAMEPLATE.
- 4.) MAY BE FACTORY INSTALLED-MOUNTED AND WIRED ON EVAPORATOR

TERMINALS

- - COMPONENT TERMINAL
- - TERMINAL BLOCK TERMINAL

CONDUCTORS/WIRING

- FACTORY WIRING
- - - - - WIRING BY OTHERS
- OPTIONAL FACTORY OR BY OTHERS

ALL FIELD WIRING MUST BE DONE IN COMPLIANCE WITH ALL APPLICABLE LOCAL AND NATIONAL CODES.

REVISIONS		DIAGRAM NUMBER
DATE	LTR	1084655-AD
-	-	

TROUBLESHOOTING GUIDE

WARNING: These guidelines are intended only for qualified service personnel familiar with troubleshooting procedures at hazardous high voltage.

Always keep all incoming field power wires away from the electronic and microprocessor area. Use shielded area provided.

Problem	Possible Solutions
<p>SmartVap II™ control display does not power up or light up display</p>	<ol style="list-style-type: none"> 1. Check for correct voltage (120 or 230V) at entering L1-L2(N) pig tails. Check main supply (fuses or breakers) 2. Check voltage on SmartVap board downstream of fuses (use terminal 1 and N). If required correct wiring fault and replace SmartVap 15A fuses (type MDA or equiv.-must be time delay type 250V rated) 3. Check SmartVap transformer for correct jumper wiring. For 230V mode single jumper should be between terminal A and B. If 120V mode jumpers should be between A and 1, also B and N. (refer to diagram) 4. Turn main power off (at least 30 seconds) and then turn back on. Re-boot SmartVap control (push UP and DOWN button together for 5 seconds until “Ed” for Electric Defrost mode or “Ad” Air Defrost appears in the display. Check all user programmed settings (time of day, room temp set point, defrost schedules etc...) and re-adjust as required.
<p>Evaporator fans do not start (Display OK and powers up)</p>	<ol style="list-style-type: none"> 1. Check to see if SmartVap is in Defrost mode (orange LED lit). Evaporator fans in Electric Defrost mode are designed NOT to run. After a defrost cycle the fans will not run until the fan delay has timed out. (Factory pre-set at 3 minutes- if too long, re-adjust accordingly) 2. On Electric Defrost model check to see if jumper is installed feeding power from terminal 1 to C (see diagram). 3. On Electric Defrost model check for correct voltage between terminal F and N. 4. Re-boot control (push UP and DOWN button together for 5 seconds until “Ed” for Electric Defrost mode appears in the display) 5. Check motor harness, motor power plug, and check for correct motor voltage (see motor dataplate). 6. Replace fan motor.
<p>Refrigeration cycle will not start (Display OK and powers up)</p>	<ol style="list-style-type: none"> 1. Check to see if SmartVap is in Refrigeration mode (Green LED lit). Re-adjust room set point accordingly. 2. Check to see if Liquid Solenoid valve is energized. (Coil has correct voltage and is magnetized) 3. Check to see if Low pressure control at compressor has closed and has the correct cut-in setting (use manifold gauge) <i>Note: this cut-in pressure setting must be below the coldest expected compressor ambient (saturated temperature /pressure equivalent)</i>

TROUBLESHOOTING GUIDE (cont'd.)

Problem	Possible Solutions
<p>Defrost heaters do not energize or heat up properly (Display OK and powers up)</p>	<ol style="list-style-type: none"> 1. Check that SmartVap is actually in Defrost mode (Orange LED lit). Re-adjust defrost schedule accordingly. <i>Note: Defrost will only initiate if the evaporator surface temperature is 54 F and lower.</i> 2. Check to see if jumper or L1 power is feeding terminal 2 (see wiring diagram) 3. Check for correct voltage between terminal 3 and N. 4. Check heater amp draw for required wattage as indicated on dataplate (watts = volts x amps) 5. Check for correct heater wiring (see diagram), and all spade and splice connections are tight. 6. Check for correct heater usage (resistances and voltage rating)
<p>Display indicates “ZONE Err” or “EVAP Err” (This error code indicates a problem with the zone or evaporator sensor. SmartVap will default into constant refrigeration mode (liquid line solenoid stays energized)</p>	<ol style="list-style-type: none"> 1. Check to see that the sensors have been plugged in their correct pin location (refer to pictorial pin connector locations in wiring diagram). 2. Check for tight connection and that all wires are intact. 3. Replace sensor.
<p>Display indicates “LOC”</p>	<ol style="list-style-type: none"> 1. Control has been locked (to prevent tampering) 2. To unlock, wait for LOC to disappear from display then push Temp, Up and Down buttons together and hold for 3 seconds
<p>Poor refrigeration performance / iced up frosting problems.</p>	<ol style="list-style-type: none"> 1. Check to see if ZONE /EVAP sensors are installed in their correct location. (ZONE sensor is located in return air stream and connector is at the top location (directly below fan relay FC contacts) 2. Re-adjust defrost cycles, termination or fan delay set points to suit local conditions. 3. Also refer to regular evaporator installation manual (trouble shooting section)

Contact the factory or your local Sales Representative for further information or assistance.

NATIONAL REFRIGERATION & AIR CONDITIONING CANADA CORP.

159 ROY BLVD., BRANTFORD, ONTARIO, CANADA N3R 7K1
PHONE: 1-800-463-9517 (519)751-0444 FAX (519)753-1140

Due to National Refrigeration's policy of continuous product improvement, we reserve the right to make changes without notice.